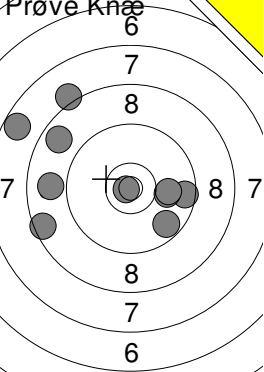
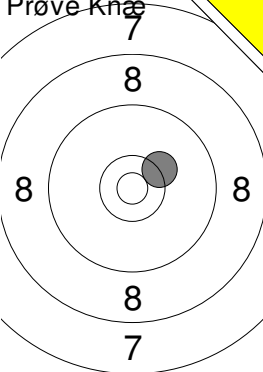
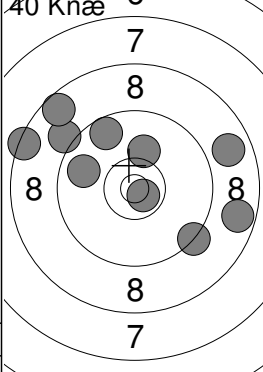
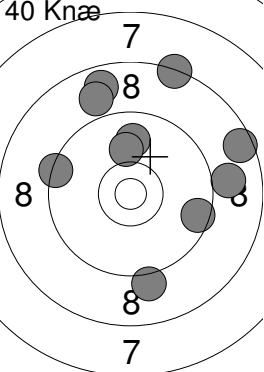
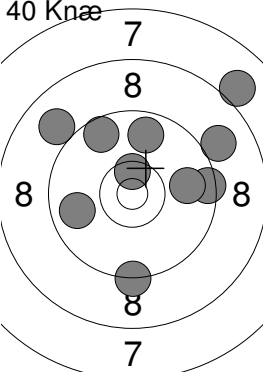
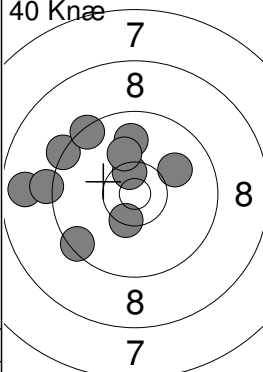
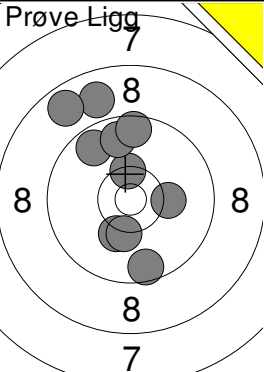
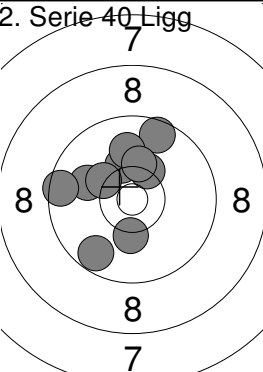
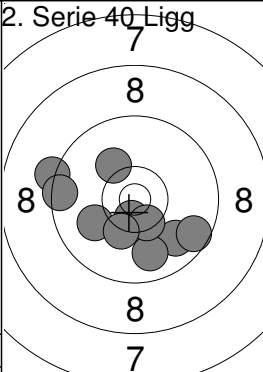
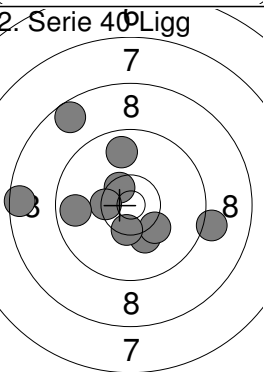
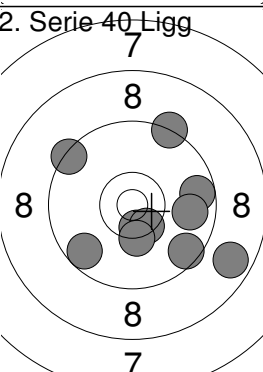
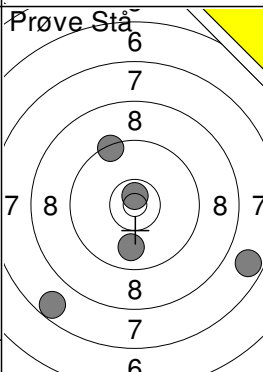
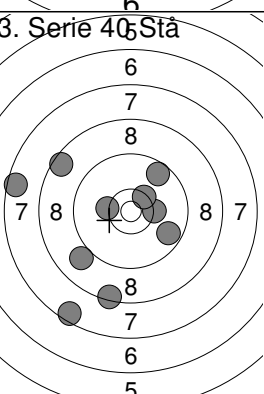
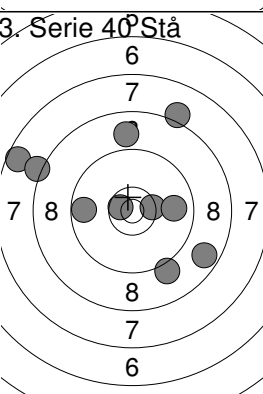
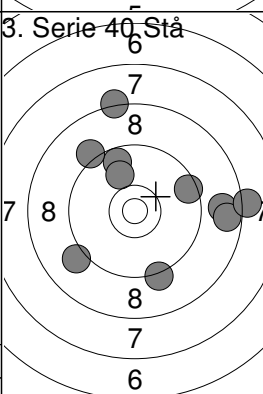

Prøve Knæ 	1: 8.9 ← 2: 9.6 → 3: 10.0 → 4: 9.7 ↓ 5: 10.0 → 6: 10.8x ← 7: 8.5 ← 8: 7.7 ↗ 9: 8.1 ↗ 10: 8.7 ↗ Serie 87.0 Total 0.0	Prøve Knæ 	11: 10.3x ↗ Serie 10.0 Total 0.0	40 Knæ 	1: 8.7 → 2: 9.1 ↗ 3: 8.8 → 4: 9.3 ↓ 5: 9.6 ↗ 6: 9.8 ↗ 7: 8.4 ↗ 8: 8.6 ↗ 9: 10.7x ↓ 10: 10.1 ↑ Serie 88.0 Total 88.0
--	--	---	--	--	--

40 Knæ 	11: 9.9 ↑ 12: 8.3 ↑ 13: 8.7 ↑ 14: 10.1 ↑ 15: 9.4 ← 16: 9.1 ↓ 17: 8.9 ↑ 18: 9.0 → 19: 8.6 → 20: 9.5 → Serie 87.0 Total 175.0	40 Knæ 	21: 8.0 ↗ 22: 9.3 ↓ 23: 10.5x ↑ 24: 9.6 ↗ 25: 9.5 → 26: 9.0 ↗ 27: 9.9 → 28: 9.8 ← 29: 9.8 ↑ 30: 9.0 ↗ Serie 90.0 Total 265.0	40 Knæ 	31: 9.9 ↑ 32: 9.3 ↗ 33: 8.8 ← 34: 9.4 ↙ 35: 9.2 ← 36: 10.5x ↑ 37: 10.1 ↑ 38: 10.4x ↓ 39: 9.4 ↗ 40: 10.0 ↗ Serie 93.0 Total 358.0
---	--	--	---	--	---

Prøve Ligg 	1: 8.9 ↑ 2: 10.2 ↓ 3: 9.6 ↓ 4: 10.3 ↓ 5: 9.7 ↗ 6: 10.4x ↑ 7: 10.2 → 8: 9.7 ↑ 9: 9.6 ↑ 10: 8.7 ↗ Serie 92.0 Total 358.0	2. Serie 40 Ligg 	1: 10.0 ← 2: 10.2 ↑ 3: 9.7 ↓ 4: 10.3x ↑ 5: 9.6 ↑ 6: 9.5 ← 7: 10.3 ↗ 8: 10.0 ↑ 9: 10.2 ↑ 10: 10.2 ↓ Serie 97.0 Total 455.0	2. Serie 40 Ligg 	11: 9.8 ↓ 12: 9.3 ↗ 13: 9.6 ↓ 14: 10.6x ↓ 15: 10.0 ← 16: 9.5 ← 17: 9.9 ↓ 18: 10.4x ↓ 19: 10.2 ↗ 20: 10.3 ↓ Serie 95.0 Total 550.0
--	---	---	--	---	--

2. Serie 40 Ligg 	21: 8.5 ← 22: 10.2 ↓ 23: 9.1 → 24: 10.5x ↗ 25: 8.6 ↗ 26: 10.4x ← 27: 10.2 ↓ 28: 9.8 ← 29: 9.8 ↑ 30: 10.4x ↓ Serie 93.0 Total 643.0	2. Serie 40 Ligg 	31: 9.4 ↗ 32: 10.5x ↓ 33: 8.7 → 34: 9.6 ↙ 35: 9.7 ↙ 36: 10.4x ↓ 37: 10.3x ↓ 38: 9.3 ↑ 39: 9.7 → 40: 9.8 → Serie 92.0 Total 735.0	Prøve Stå 	1: 7.7 → 2: 9.9 ↓ 3: 10.7x ↑ 4: 7.7 ↙ 5: 9.4 ↗ Serie 42.0 Total 735.0
---	---	--	---	---	---

3. Serie 40 Stå 	1: 8.4 ↓ 2: 8.6 ↗ 3: 10.3 → 4: 9.0 ↙ 5: 10.3 ← 6: 7.6 ← 7: 7.5 ↓ 8: 9.6 ↗ 9: 10.4x ↗ 10: 9.7 → Serie 87.0 Total 822.0	3. Serie 40 Stå 	11: 8.9 ↑ 12: 7.6 ↗ 13: 9.7 ← 14: 8.2 ↗ 15: 9.1 ↓ 16: 8.1 ↗ 17: 10.4x → 18: 10.6x ← 19: 9.8 → 20: 8.7 ↙ Serie 86.0 Total 908.0	3. Serie 40 Stå 	21: 9.5 → 22: 8.2 ↑ 23: 9.7 ↗ 24: 8.8 → 25: 8.7 → 26: 9.1 ↗ 27: 8.1 → 28: 9.1 ↙ 29: 9.2 ↓ 30: 10.0 ↑ Serie 87.0 Total 995.0
--	--	---	---	---	--

3. Serie 40 Stå

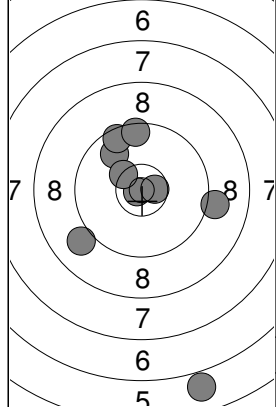

- 31: 10.8x ←
- 32: 9.8 ↗
- 33: 9.5 ↗
- 34: 9.5 ↑
- 35: 5.9 ↓
- 36: 9.1 →
- 37: 9.0 ↙
- 38: 10.4x ↗
- 39: 10.6x →

Serie 80.0

Total 1075.0

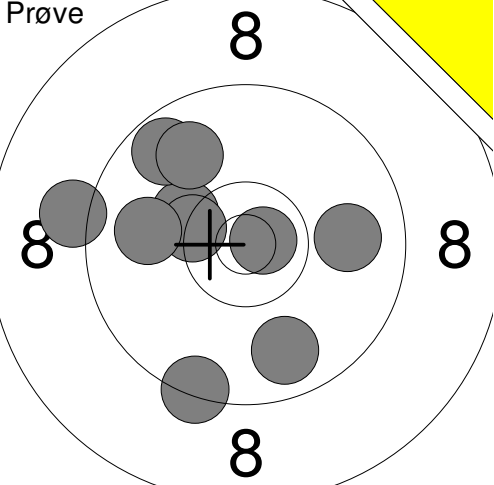
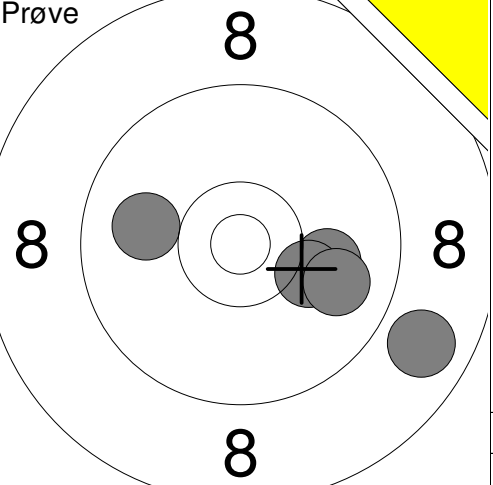
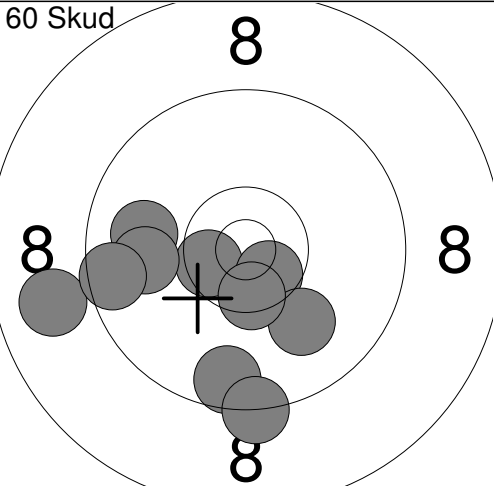
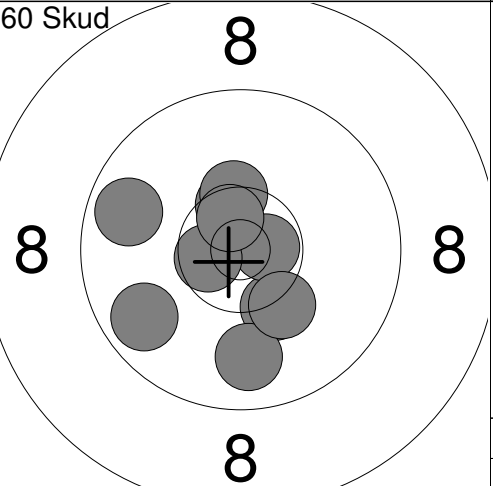
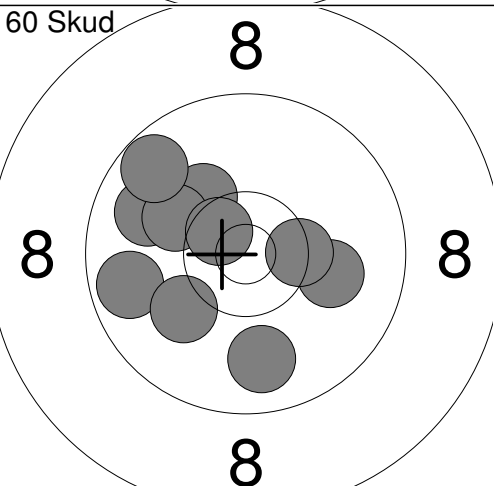
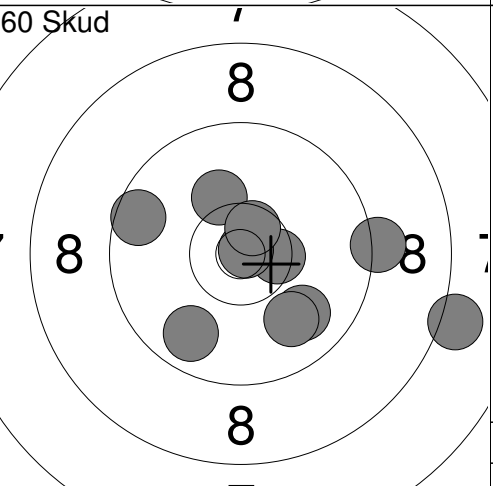
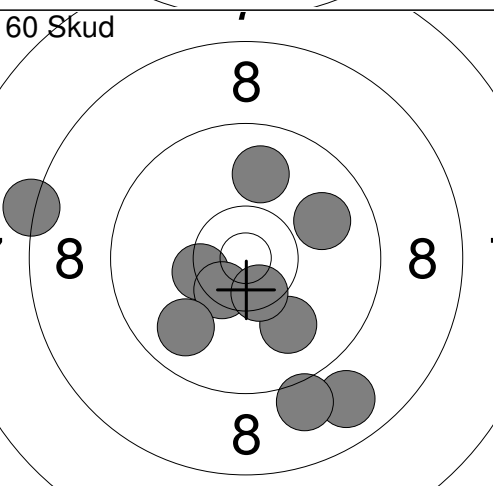
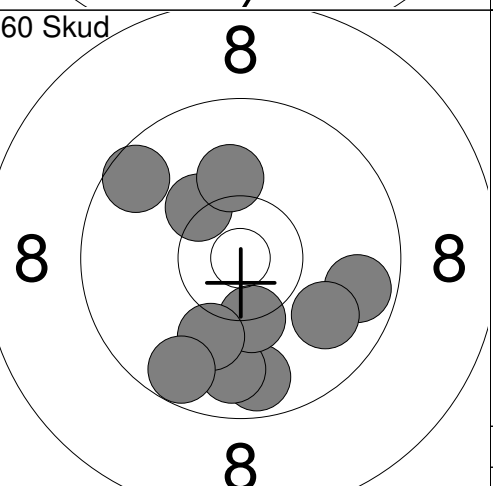
Hold	Skive	Morten Larsen	
2	1		
50m		Vester Hassing	
31.05.2015		DSU stævne 2015	Aalborg Skyttekreds
Prøve		1: 9.9 → 2: 9.1 ← 3: 9.4 ↓ 4: 10.2 ↗ 5: 9.7 ↗ 6: 10.4x ← 7: 9.9 ← 8: 10.8x → 9: 9.9 ↗ 10: 9.8 ↓ Serie 99.1 Total 0.0	Prøve  11: 8.8 ↘ 12: 10.0 → 13: 10.2 ↘ 14: 10.0 ← 15: 9.9 ↘ Serie 48.9 Total 0.0
60 Skud		1: 10.5x ← 2: 9.9 ← 3: 8.9 ← 4: 9.6 ↓ 5: 9.9 ← 6: 9.6 ← 7: 10.6x ↓ 8: 9.3 ↓ 9: 10.0 ↓ 10: 10.5x ↓ Serie 98.8 Total 98.8	60 Skud  11: 10.3 ↓ 12: 9.8 ↓ 13: 10.7x → 14: 9.7 ← 15: 10.2 ↓ 16: 10.5x ↑ 17: 9.7 ← 18: 10.4x ↑ 19: 10.6x ← 20: 10.6x ↑ Serie 102.5 Total 201.3
60 Skud		21: 9.9 ↗ 22: 10.2 ↗ 23: 10.1 ↗ 24: 9.7 ← 25: 10.1 → 26: 10.6x ↗ 27: 10.4x → 28: 9.7 ↗ 29: 10.1 ← 30: 9.9 ↓ Serie 100.7 Total 302.0	60 Skud  31: 9.9 ↘ 32: 9.6 ← 33: 10.5x → 34: 9.9 ↘ 35: 10.9x ↗ 36: 10.2 ↑ 37: 9.8 ↘ 38: 8.1 → 39: 10.6x ↑ 40: 9.2 → Serie 98.7 Total 400.7
60 Skud		41: 9.9 ↑ 42: 10.0 ↓ 43: 10.4x ← 44: 9.9 → 45: 10.5x ↓ 46: 10.5x ↓ 47: 9.8 ↘ 48: 8.8 ↘ 49: 8.3 ← 50: 9.1 ↓ Serie 97.2 Total 497.9	60 Skud  51: 9.7 ↓ 52: 9.7 → 53: 10.3 ↗ 54: 10.1 ↑ 55: 9.8 ↓ 56: 9.6 ↗ 57: 10.3x ↓ 58: 9.9 ↘ 59: 10.1 ↓ 60: 9.6 ↓ Serie 99.1 Total 597.0

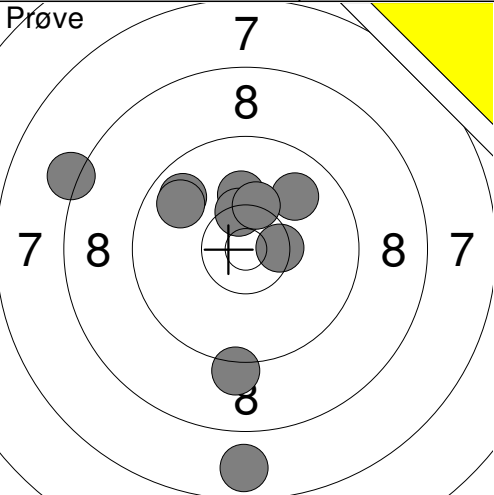
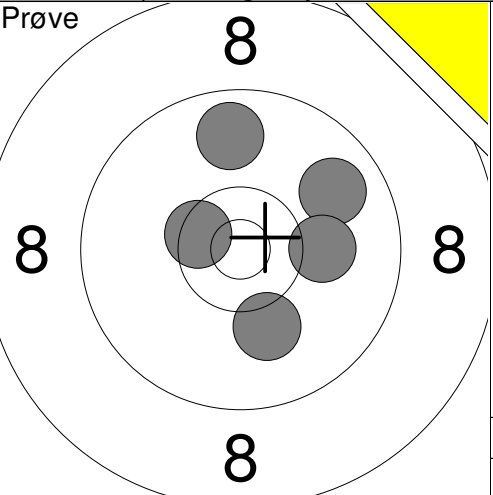
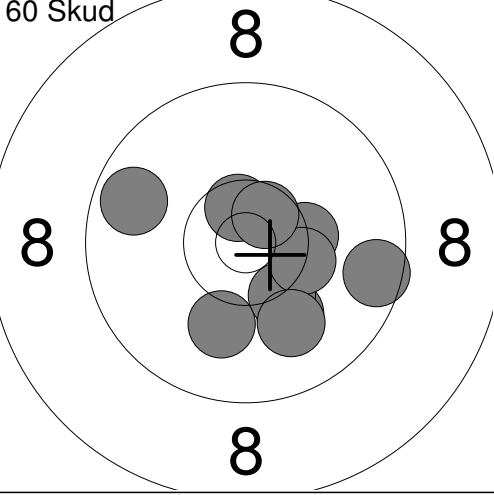
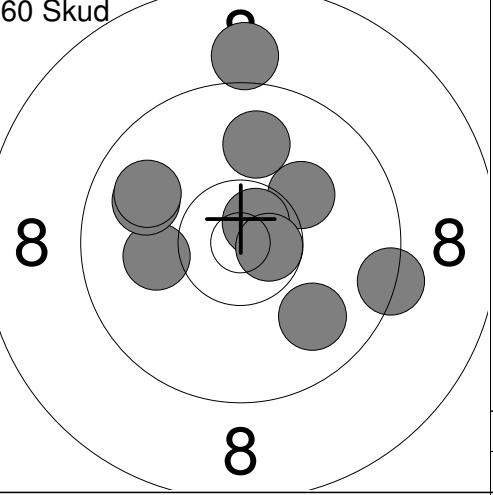
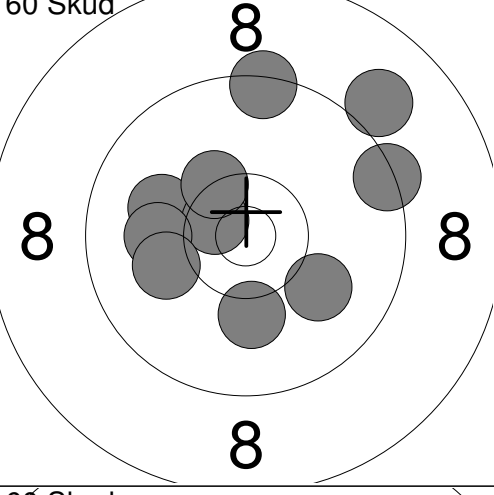
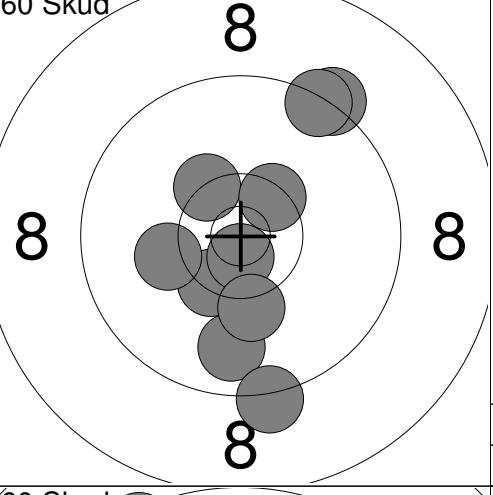
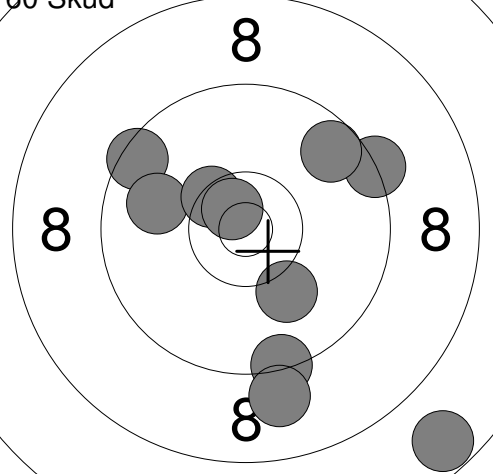
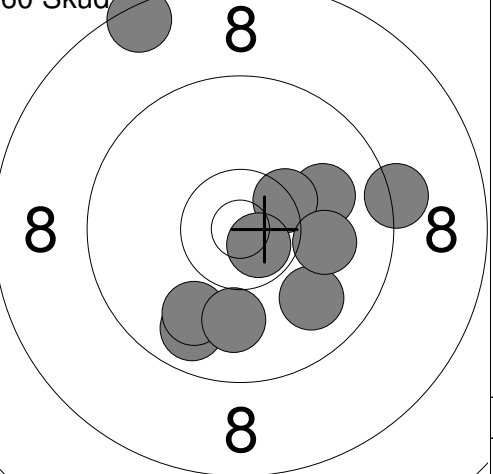
Hold	Skive	Christine Jacobi	
2	2		
50m		Viborg Skytteforening	
31.05.2015		DSU stævne 2015	Aalborg Skyttekreds
Prøve		1: 7.8 ↓ 2: 9.2 ↓ 3: 10.5x → 4: 9.8 ↗ 5: 10.2 ↑ 6: 10.4x ↑ 7: 8.2 ↖ 8: 9.8 ↗ 9: 9.9 ↗ 10: 10.3x ↑ Serie 96.1 Total 0.0	Prøve  11: 9.8 ↑ 12: 10.1 ↓ 13: 9.8 ↗ 14: 10.1 → 15: 10.5x ← Serie 50.3 Total 0.0
60 Skud		1: 10.3x → 2: 10.1 ↓ 3: 10.3 ↓ 4: 10.6x ↑ 5: 9.7 ↗ 6: 10.1 ↓ 7: 9.6 → 8: 10.3x → 9: 10.0 ↓ 10: 10.6x ↗ Serie 101.6 Total 101.6	60 Skud  11: 9.0 ↑ 12: 10.1 ← 13: 10.2 ↗ 14: 10.7x ↗ 15: 9.9 ← 16: 9.9 ↖ 17: 9.9 ↓ 18: 10.7x → 19: 9.9 ↑ 20: 9.3 → Serie 99.6 Total 201.2
60 Skud		21: 10.1 ↓ 22: 10.0 ← 23: 10.0 ↓ 24: 9.0 ↗ 25: 10.6x ↗ 26: 9.4 ↑ 27: 9.4 → 28: 10.3x ↗ 29: 10.0 ← 30: 10.1 ← Serie 98.9 Total 300.1	60 Skud  31: 9.8 ↓ 32: 9.2 ↓ 33: 9.3 ↗ 34: 10.4x ↓ 35: 10.7x ↓ 36: 10.2 ↓ 37: 10.2 ← 38: 9.4 ↗ 39: 10.3x ↖ 40: 10.4x ↗ Serie 99.9 Total 400.0
60 Skud		41: 9.5 ↖ 42: 7.7 ↓ 43: 9.9 ↖ 44: 10.1 ↓ 45: 9.3 → 46: 10.4x ↗ 47: 10.7x ↗ 48: 9.6 ↗ 49: 9.4 ↓ 50: 9.0 ↓ Serie 95.6 Total 495.6	60 Skud  51: 9.2 → 52: 10.0 → 53: 10.4x ↗ 54: 9.9 ↓ 55: 9.8 ↓ 56: 9.9 ↓ 57: 10.7x → 58: 10.0 ↓ 59: 8.5 ↗ 60: 10.0 → Serie 98.4 Total 594.0

Hold	Skive	Caroline Jacobi	
2	3		
50m		Viborg Skytteforening	
31.05.2015		DSU stævne 2015	Aalborg Skyttekreds
Prøve Knæ 	1: 9.1 2: 9.5 3: 8.5 4: 5.8 5: 9.6 6: 7.9 7: 9.0 8: 8.3 9: 10.2 10: 10.3 Serie 84.0 Total 0.0	Prøve Knæ 	11: 9.5 12: 10.0 13: 6.6 14: 10.3x Serie 35.0 Total 0.0
Knæ 	1: 7.7 2: 8.3 3: 10.2 4: 8.9 5: 10.2 6: 10.8x 7: 8.3 8: 10.2 9: 8.3 10: 9.6 Serie 88.0 Total 88.0	Prøve Ligg 	1: 9.6 2: 9.8 3: 8.5 4: 9.7 5: 9.8 6: 10.7x 7: 9.3 8: 8.7 9: 9.5 10: 10.0 Serie 90.0 Total 88.0
Prøve Ligg 	11: 10.1 12: 10.1 13: 9.7 14: 10.6x 15: 9.6 16: 10.0 Serie 58.0 Total 88.0	2. Serie 40 Ligg 	1: 10.2 2: 8.9 3: 9.6 4: 9.9 5: 10.7x 6: 10.5x 7: 10.3x 8: 10.3x 9: 9.5 10: 10.0 Serie 95.0 Total 183.0
2. Serie 40 Ligg 	11: 9.9 12: 10.7x 13: 10.2 14: 9.7 15: 9.0 16: 9.8 17: 10.6x 18: 10.7x 19: 9.5 20: 10.4x Serie 95.0 Total 278.0	2. Serie 40 Ligg 	21: 9.8 22: 8.5 23: 10.3 24: 9.7 25: 9.8 26: 9.8 27: 10.7x 28: 9.7 29: 10.0 30: 9.2 Serie 92.0 Total 370.0
2. Serie 40 Ligg 	31: 9.3 32: 8.5 33: 10.7x 34: 10.5x 35: 10.5x 36: 10.0 37: 10.0 38: 10.4x 39: 9.9 40: 10.4x Serie 96.0 Total 466.0	Prøve Stå 	1: 9.4 2: 7.0 3: 9.0 4: 9.2 5: 9.5 6: 9.4 7: 5.3 8: 9.4 9: 8.3 10: 9.0 Serie 83.0 Total 466.0
3. Serie Stå 	1: 8.7 2: 8.6 3: 9.3 4: 7.1 5: 8.6 6: 9.2 7: 8.9 8: 8.8 9: 10.2 10: 7.4 Serie 82.0 Total 548.0		

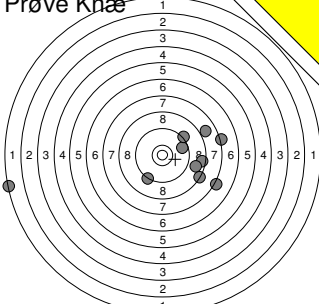
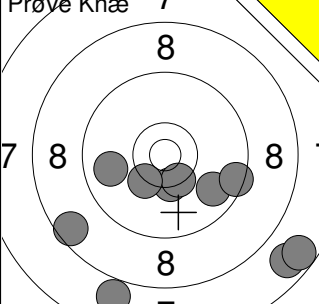
Prøve Knæ 	1: 9.7 → 2: 7.2 ↘ 3: 7.2 ↘ 4: 7.9 → 5: 1.4 ← 6: 8.5 → 7: 8.8 → 8: 9.3 → 9: 9.3 → 10: 8.3 ↘	Prøve Knæ 	11: 9.8 ↘ 12: 8.6 ↘ 13: 9.8 ← 14: 9.4 → 15: 7.9 ↘ 16: 7.7 ↘ 17: 10.3x ↘ 18: 10.4x ↘ 19: 7.7 ↘ 20: 10.3x ↘
Serie	73.0	Serie	86.0
Total	0.0	Total	0.0

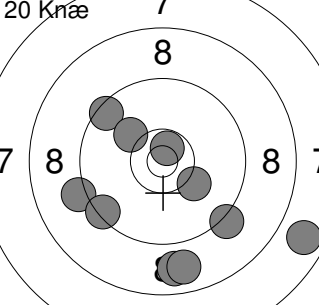
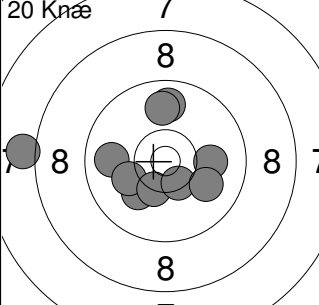
20 Knæ 	1: 7.8 → 2: 8.8 ↘ 3: 8.8 ↘ 4: 9.2 ← 5: 10.7x ↑ 6: 9.2 ↘ 7: 10.2 ↘ 8: 9.5 ↘ 9: 9.4 ↘ 10: 10.1 ↘	20 Knæ 	11: 10.0 → 12: 9.9 ← 13: 10.1 ↘ 14: 9.8 ↘ 15: 10.1 ↘ 16: 10.3x ↘ 17: 9.9 ↘ 18: 10.4x ↘ 19: 8.1 ↘ 20: 10.0 ↘
Serie	89.0	Serie	95.0
Total	89.0	Total	184.0

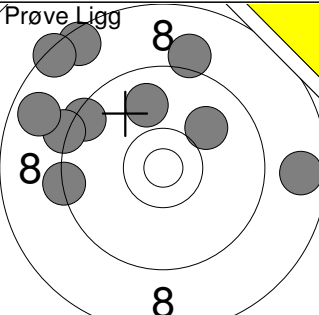
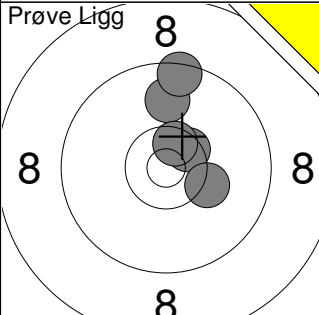
Prøve Ligg 	1: 8.5 ↘ 2: 9.3 ← 3: 9.5 ↘ 4: 8.4 ↘ 5: 9.2 ↘ 6: 8.8 ↘ 7: 9.1 ↘ 8: 9.9 ↘ 9: 10.0 ↘ 10: 8.7 →	Prøve Ligg 	11: 10.5x ↘ 12: 9.9 ↘ 13: 10.5x ↘ 14: 10.3 ↘ 15: 9.5 ↘
Serie	87.0	Serie	48.0
Total	184.0	Total	184.0

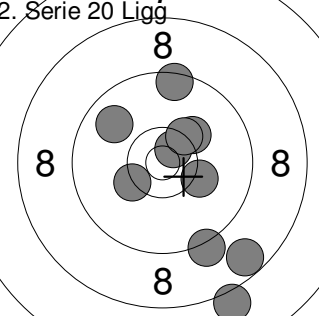
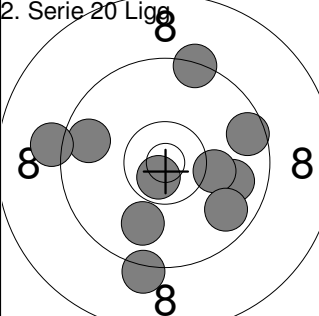
2. Serie 20 Ligg 	1: 9.2 ↘ 2: 8.7 ↘ 3: 8.1 ↘ 4: 10.6x ↘ 5: 9.8 ↘ 6: 10.2 ↘ 7: 10.3x ↘ 8: 9.5 ↘ 9: 10.2 ↘ 10: 10.3 ↘	2. Serie 20 Ligg 	11: 9.9 ↘ 12: 9.7 ↘ 13: 9.4 ↘ 14: 9.1 ↘ 15: 10.2 ↘ 16: 9.8 ↘ 17: 9.9 ↘ 18: 9.2 ↘ 19: 9.6 ↘ 20: 10.7x ↘
Serie	93.0	Serie	92.0
Total	277.0	Total	369.0

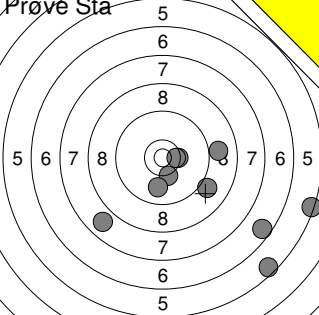
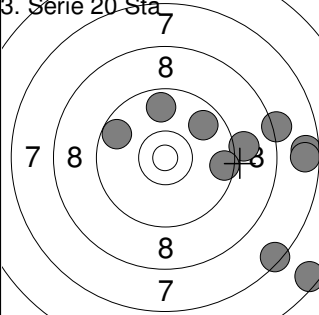
Prøve Stå 	1: 6.6 ↘ 2: 10.3 ↘ 3: 9.0 ↘ 4: 5.4 ↘ 5: 10.4x ↘ 6: 10.5x ↘ 7: 9.0 ↘ 8: 9.9 ↘ 9: 5.6 ↘ 10: 7.8 ↘	3. Serie 20 Stå 	1: 9.7 ↘ 2: 9.7 ↘ 3: 9.1 ↘ 4: 8.2 ↘ 5: 9.8 ↘ 6: 9.5 ↘ 7: 7.5 ↘ 8: 7.6 ↘ 9: 7.6 ↘ 10: 6.5 ↘
Serie	80.0	Serie	80.0
Total	369.0	Total	449.0

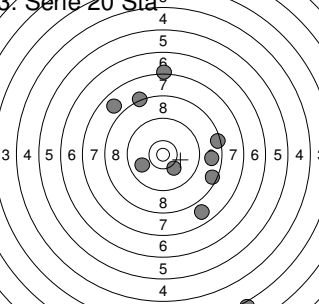
3. Serie 20 Stå³ 	11: 7.2 ↘ 12: 8.2 ↘ 13: 7.8 ↘ 14: 8.4 ↘ 15: 8.5 ↘ 16: 7.8 ↘ 17: 10.2 ↘ 18: 9.9 ↘ 19: 3.1 ↘ 20: 8.8 ↘		
Serie	75.0		
Total	524.0		

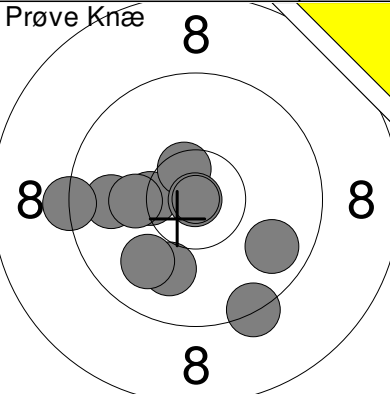
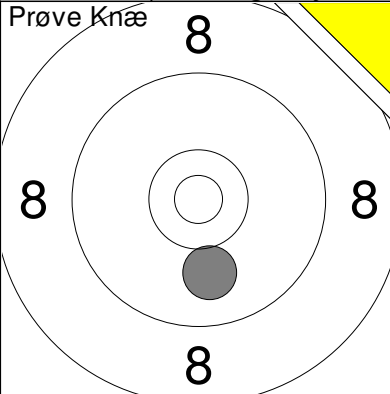
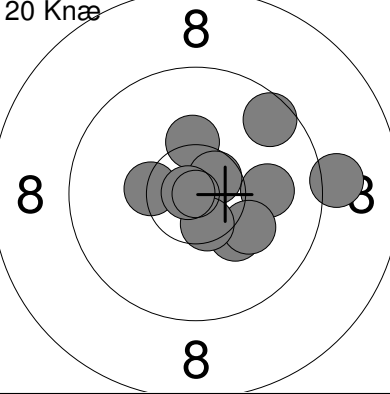
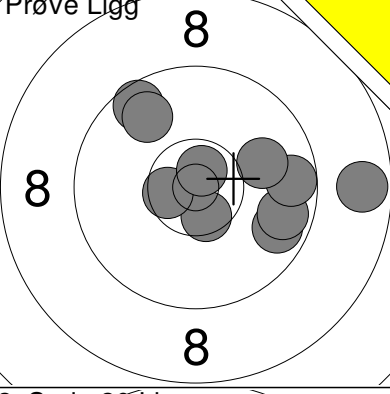
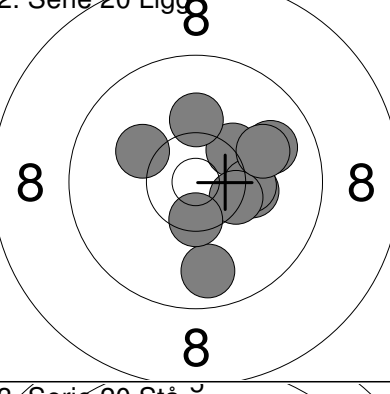
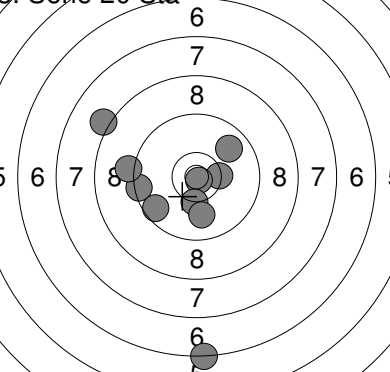
Hold	Skive	Jette Faurbye		
2	5			
50m	Viborg Skytteforening			
31.05.2015	DSU stævne 2015		Aalborg Skyttekreds	
Prøve Knæ		1: 10.0 2: 9.9 3: 9.8 4: 9.8 5: 10.4x 6: 10.5x 7: 10.2 8: 9.3 9: 9.3 10: 10.9x	Prøve Knæ	 11: 10.0
	Serie 95.0 Total 0.0		Serie 10.0 Total 0.0	
20 Knæ		1: 10.3 2: 10.6x 3: 10.2 4: 10.4x 5: 10.0 6: 10.1 7: 10.5x 8: 9.6 9: 9.1 10: 10.8x	20 Knæ	11: 9.8 12: 10.4x 13: 9.8 14: 9.7 15: 9.7 16: 10.4x 17: 9.9 18: 10.0 19: 9.9 20: 10.2
	Serie 98.0 Total 98.0		Serie 94.0 Total 192.0	
Prøve Ligg		1: 10.5x 2: 9.7 3: 9.7 4: 9.7 5: 8.7 6: 9.6 7: 10.0 8: 9.8 9: 10.6x 10: 10.7x	2. Serie 20 Ligg	1: 10.5x 2: 10.4x 3: 9.9 4: 9.8 5: 10.0 6: 9.9 7: 9.6 8: 10.5x 9: 9.4 10: 10.2
	Serie 93.0 Total 192.0		Serie 95.0 Total 287.0	
2. Serie 20 Ligg		11: 10.3x 12: 10.2 13: 10.2 14: 10.2 15: 10.4x 16: 9.9 17: 10.0 18: 9.8 19: 10.5x 20: 10.1	Prøve Stå	1: 9.4 2: 10.2 3: 9.2
	Serie 98.0 Total 385.0		Serie 28.0 Total 385.0	
3. Serie 20 Stå		1: 9.8 2: 10.4x 3: 6.3 4: 8.1 5: 9.4 6: 10.9x 7: 9.6 8: 9.2 9: 10.3x 10: 10.0	3. Serie 20 Stå	11: 9.9 12: 10.5x 13: 9.7 14: 9.4 15: 8.5 16: 8.5 17: 9.3 18: 9.4 19: 9.1 20: 8.4
	Serie 90.0 Total 475.0		Serie 88.0 Total 563.0	

Hold	Skive	Christinna Herskind			
2	6				
50m		Aalborg Skyttekreds			
31.05.2015		DSU stævne 2015		Aalborg Skyttekreds	
Prøve Knæ		1: 6.6 ↑	Prøve Knæ	11: 9.7 ↘	
		2: 7.4 ↗		12: 8.8 ↓	
		3: 7.6 ↘		13: 9.7 →	
		4: 9.7 ↖		14: 9.8 →	
		5: 9.9 ↖		15: 9.7 ↑	
		6: 9.7 ←			
		7: 9.4 ↓			
		8: 10.6x ↗			
		9: 10.1 ↓			
		10: 9.2 ↓			
		Serie 85.0		Serie 44.0	
		Total 0.0		Total 0.0	
20 Knæ		1: 10.6x ←	20 Knæ	11: 9.2 →	
		2: 9.3 ↗		12: 9.9 ↓	
		3: 10.2 ↘		13: 10.5x ↖	
		4: 9.4 ↓		14: 10.1 →	
		5: 9.9 ↑		15: 10.0 →	
		6: 9.5 ↓		16: 10.0 →	
		7: 10.3x ↑		17: 9.6 →	
		8: 10.7x ↑		18: 9.8 →	
		9: 8.8 ←		19: 10.6x ↓	
		10: 10.3x →		20: 10.0 ↓	
		Serie 94.0		Serie 96.0	
		Total 94.0		Total 190.0	
Prøve Ligg		1: 7.7 ←	2. Serie 20 Ligg	1: 10.1 ↓	
		2: 9.7 ↗		2: 10.2 ←	
		3: 7.8 ↖		3: 10.6x ↗	
		4: 9.9 ↗		4: 10.0 ←	
		5: 10.3x ←		5: 10.2 ↗	
		6: 9.8 ↓		6: 8.8 ↗	
		7: 10.3 ↓		7: 10.1 ↓	
		8: 10.0 ↗		8: 10.2 ↓	
		9: 10.3 ↓		9: 10.4x ↗	
				10: 10.1 ↖	
		Serie 81.0		Serie 98.0	
		Total 190.0		Total 288.0	
2. Serie 20 Ligg		11: 9.7 ↓	Prøve Stå	1: 8.9 ←	
		12: 10.4x ↓		2: 10.0 ↓	
		13: 9.5 ↘		3: 9.9 →	
		14: 8.6 ↗		4: 9.2 ←	
		15: 9.1 ↖			
		16: 9.6 ←			
		17: 10.2 →			
		18: 10.3 ↖			
		19: 10.0 ↗			
		20: 9.9 ←			
		Serie 93.0		Serie 36.0	
		Total 381.0		Total 381.0	
3. Serie 20 Stå		1: 10.7x →	3. Serie 20 Stå	11: 7.6 ↑	
		2: 5.8 ↗		12: 9.0 →	
		3: 10.2 ↘		13: 9.5 ↗	
		4: 10.5x ↘		14: 6.6 ↗	
		5: 8.5 ↗		15: 8.3 ↓	
		6: 7.9 →		16: 10.9x ↓	
		7: 8.6 →		17: 9.6 ↑	
		8: 8.3 ←		18: 9.3 ↑	
		9: 9.6 ←		19: 8.5 →	
		10: 8.2 →		20: 8.9 ↗	
		Serie 83.0		Serie 83.0	
		Total 464.0		Total 547.0	

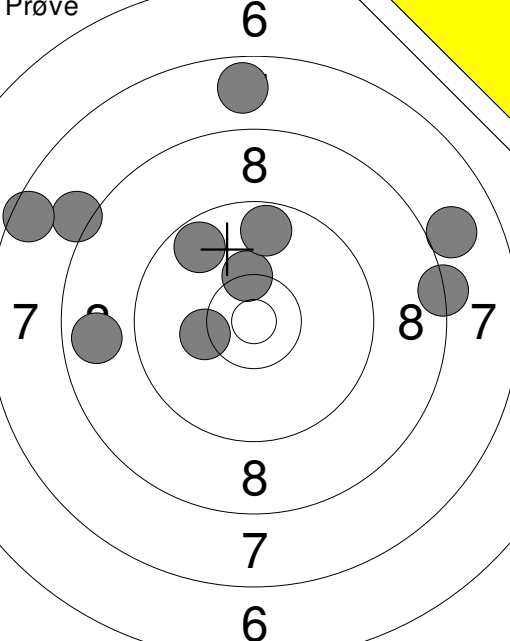
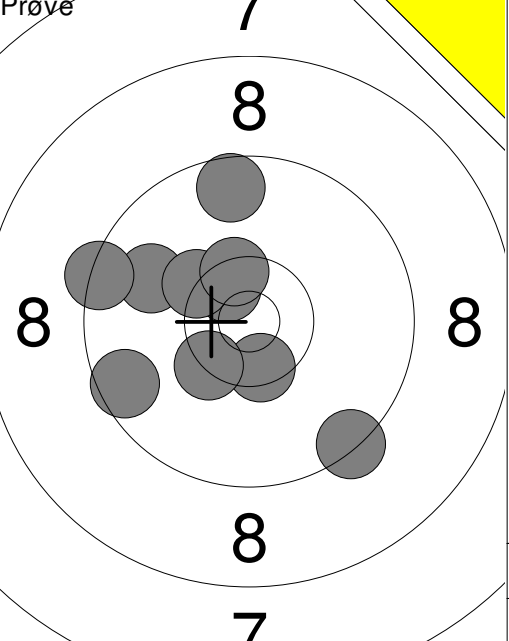
<p>Prøve 6</p> 	<p>1: 8.0 →</p> <p>2: 8.3 →</p> <p>3: 8.1 ↗</p> <p>4: 7.5 ↖</p> <p>5: 8.8 ←</p> <p>6: 10.3x ↑</p> <p>7: 7.7 ↑</p> <p>8: 10.3 ←</p> <p>9: 9.7 ↑</p> <p>10: 9.7 ↖</p> <table border="1" style="width:100%; border-collapse: collapse;"> <tr><td>Serie</td><td style="text-align:right;">88.4</td></tr> <tr><td>Total</td><td style="text-align:right;">0.0</td></tr> </table>	Serie	88.4	Total	0.0	<p>Prøve 7</p>  <p>11: 10.5x ↖</p> <p>12: 10.5x ↓</p> <p>13: 9.9 ↖</p> <p>14: 9.6 ↖</p> <p>15: 9.6 ↑</p> <p>16: 10.4x ↖</p> <p>17: 9.4 ↖</p> <p>18: 9.4 ↓</p> <p>19: 10.3x ↖</p> <p>20: 10.4x ↑</p> <table border="1" style="width:100%; border-collapse: collapse;"> <tr><td>Serie</td><td style="text-align:right;">100.0</td></tr> <tr><td>Total</td><td style="text-align:right;">0.0</td></tr> </table>	Serie	100.0	Total	0.0
Serie	88.4									
Total	0.0									
Serie	100.0									
Total	0.0									

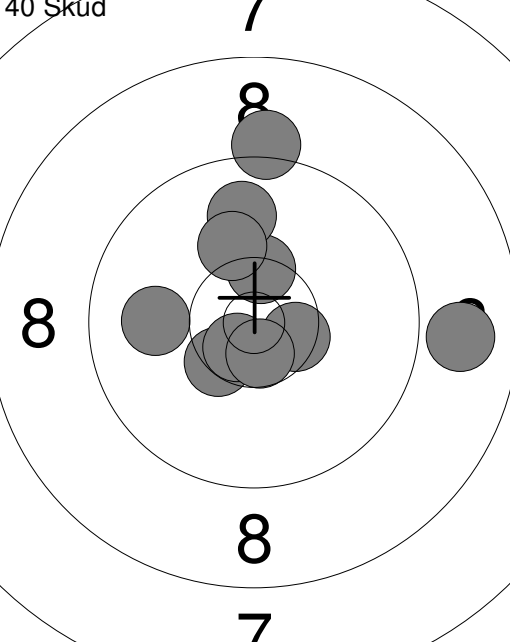
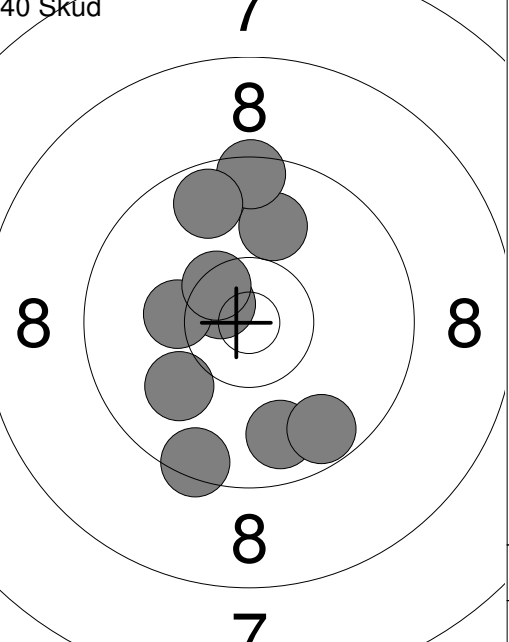
<p>40 Skud 7</p>  <table border="1" style="width:100%; border-collapse: collapse;"> <tr><td>Serie</td><td style="text-align:right;">100.8</td></tr> <tr><td>Total</td><td style="text-align:right;">100.8</td></tr> </table>	Serie	100.8	Total	100.8	<p>1: 10.5x →</p> <p>2: 9.2 ↑</p> <p>3: 8.9 →</p> <p>4: 10.4x ↖</p> <p>5: 10.7x ↖</p> <p>6: 10.4x ↑</p> <p>7: 10.6x ↓</p> <p>8: 9.9 ↑</p> <p>9: 10.2 ↑</p> <p>10: 10.0 ←</p> <table border="1" style="width:100%; border-collapse: collapse;"> <tr><td>Serie</td><td style="text-align:right;">100.8</td></tr> <tr><td>Total</td><td style="text-align:right;">100.8</td></tr> </table>	Serie	100.8	Total	100.8	<p>40 Skud 7</p>  <p>11: 9.8 ↓</p> <p>12: 9.5 ↓</p> <p>13: 10.0 ↑</p> <p>14: 9.5 ↑</p> <p>15: 9.7 ↑</p> <p>16: 10.6x ↖</p> <p>17: 10.0 ↖</p> <p>18: 10.2 ←</p> <p>19: 9.7 ↓</p> <p>20: 10.5x ↖</p> <table border="1" style="width:100%; border-collapse: collapse;"> <tr><td>Serie</td><td style="text-align:right;">99.5</td></tr> <tr><td>Total</td><td style="text-align:right;">200.3</td></tr> </table>	Serie	99.5	Total	200.3
Serie	100.8													
Total	100.8													
Serie	100.8													
Total	100.8													
Serie	99.5													
Total	200.3													

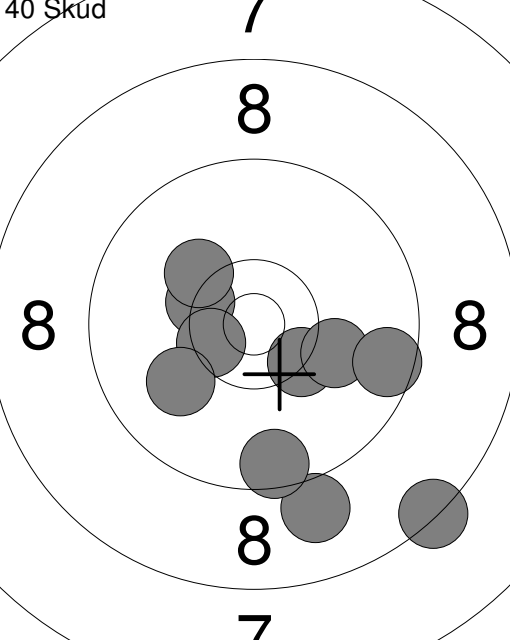
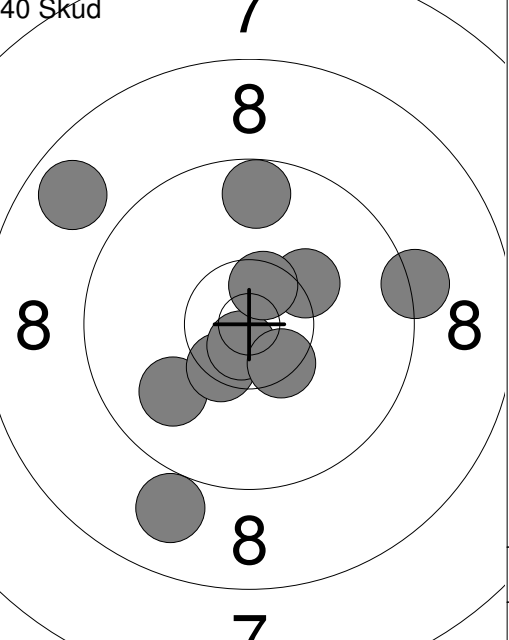
<p>40 Skud 7</p>  <table border="1" style="width:100%; border-collapse: collapse;"> <tr><td>Serie</td><td style="text-align:right;">97.9</td></tr> <tr><td>Total</td><td style="text-align:right;">298.2</td></tr> </table>	Serie	97.9	Total	298.2	<p>21: 10.4x ↖</p> <p>22: 8.3 ↓</p> <p>23: 10.5x ↖</p> <p>24: 10.0 ↖</p> <p>25: 9.0 ↓</p> <p>26: 10.2 ↗</p> <p>27: 9.5 ↓</p> <p>28: 10.3x ↖</p> <p>29: 10.1 →</p> <p>30: 9.6 →</p> <table border="1" style="width:100%; border-collapse: collapse;"> <tr><td>Serie</td><td style="text-align:right;">97.9</td></tr> <tr><td>Total</td><td style="text-align:right;">298.2</td></tr> </table>	Serie	97.9	Total	298.2	<p>40 Skud 7</p>  <p>31: 9.9 ↖</p> <p>32: 10.4x ↖</p> <p>33: 8.8 ↖</p> <p>34: 10.7x ↖</p> <p>35: 9.7 ↑</p> <p>36: 10.3 ↗</p> <p>37: 10.5x ↑</p> <p>38: 10.4x ↖</p> <p>39: 9.0 ↓</p> <p>40: 9.2 →</p> <table border="1" style="width:100%; border-collapse: collapse;"> <tr><td>Serie</td><td style="text-align:right;">98.9</td></tr> <tr><td>Total</td><td style="text-align:right;">397.1</td></tr> </table>	Serie	98.9	Total	397.1
Serie	97.9													
Total	298.2													
Serie	97.9													
Total	298.2													
Serie	98.9													
Total	397.1													

Prøve 	1: 8.7 ↙ 2: 9.7 ← 3: 8.9 ↙ 4: 7.8 ← 5: 9.4 ↗ 6: 9.6 ↗ 7: 9.4 ↑ 8: 9.8 ↗ 9: 10.4x ↗ 10: 8.8 ↓ Serie 92.5 Total 0.0	Prøve 		11: 10.0 → 12: 10.0 ↘ 13: 10.2 → 14: 10.0 ↓ 15: 9.8 ↘ Serie 50.0 Total 0.0
-----------	--	-----------	--	--

40 Skud 	1: 9.8 ← 2: 10.0 → 3: 10.5x → 4: 9.5 ← 5: 9.8 → 6: 10.2 → 7: 10.7x ↙ 8: 10.6x ↘ 9: 9.1 ↓ 10: 10.7x ↓ Serie 100.9 Total 100.9	40 Skud 		11: 9.3 ↑ 12: 10.0 ↗ 13: 9.8 ↑ 14: 9.9 ↙ 15: 10.3 ↓ 16: 9.8 ↓ 17: 8.9 ↙ 18: 10.0 ↗ 19: 10.6x ↓ 20: 10.2 ↙ Serie 98.8 Total 199.7
-------------	---	-------------	--	---

40 Skud 	21: 10.5x ↙ 22: 9.8 → 23: 9.2 → 24: 10.5x → 25: 10.4x ↓ 26: 9.4 ↗ 27: 10.7x ↙ 28: 9.8 ↑ 29: 10.1 ↑ 30: 8.7 ↑ Serie 99.1 Total 298.8	40 Skud 		31: 10.4x ↙ 32: 10.5x ↙ 33: 9.2 → 34: 10.6x ↗ 35: 10.4x ↙ 36: 10.2 ↗ 37: 9.2 ↘ 38: 9.8 ↑ 39: 10.1 ↓ 40: 8.9 → Serie 99.3 Total 398.1
-------------	--	-------------	--	---

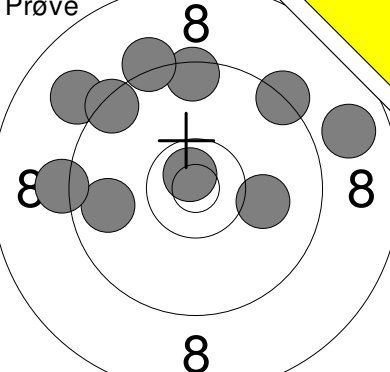
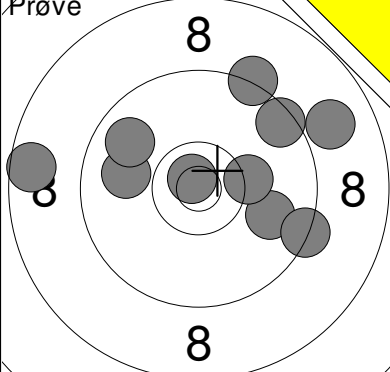
Prøve 	1: 10.1 → 2: 9.3 ↗ 3: 10.8x ↗ 4: 9.0 ↗ 5: 9.8 ← 6: 9.5 ↑ 7: 9.2 ← 8: 9.4 ↗ 9: 8.8 ↗ 10: 9.2 ↗	Prøve 	11: 8.9 ↗ 12: 9.5 ↗ 13: 9.9 ↘ 14: 9.9 ← 15: 10.2 → 16: 9.3 ↗ 17: 10.8x ↗ 18: 8.6 ← 19: 9.8 ↗ 20: 9.3 ↘
8	Serie 95.1	8	Serie 96.2
	Total 0.0		Total 0.0

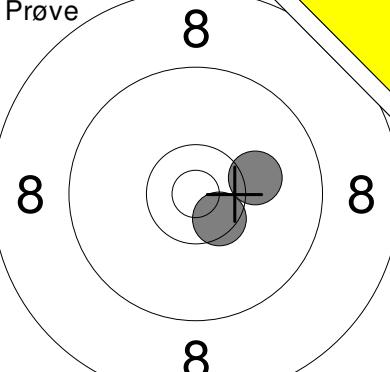
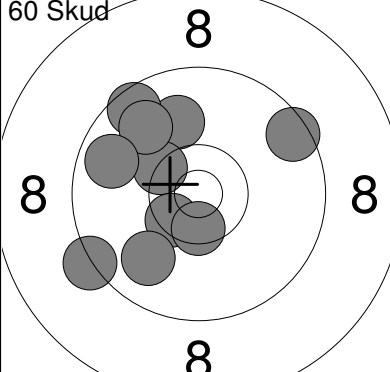
Prøve 	21: 10.1 → 22: 10.5x ↘	60 Skud 	1: 10.0 ↑ 2: 10.3x ↗ 3: 9.6 ↗ 4: 9.8 ↗ 5: 9.5 ↗ 6: 10.5x ↘ 7: 9.3 ← 8: 9.9 ↘ 9: 9.7 ↗ 10: 10.5x ↓
8	Serie 20.6	8	Serie 99.1
	Total 0.0		Total 99.1

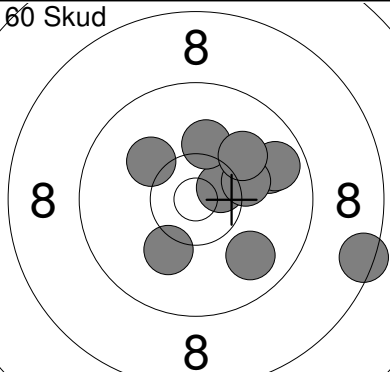
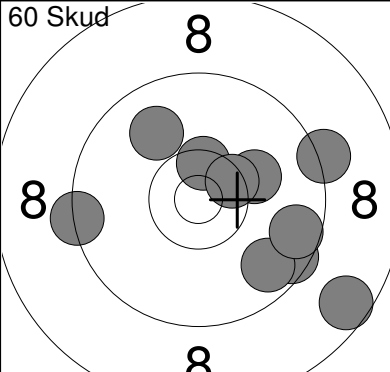
60 Skud 	11: 10.6x → 12: 9.8 → 13: 8.4 → 14: 10.1 ↘ 15: 10.2 ↑ 16: 9.8 ↘ 17: 10.1 ↗ 18: 9.7 → 19: 10.2 → 20: 10.0 ↗	60 Skud 	21: 10.2 → 22: 10.5x ↑ 23: 9.5 ↘ 24: 9.9 ↗ 25: 9.2 → 26: 8.6 ↘ 27: 9.7 ↘ 28: 9.4 ← 29: 9.6 ↘ 30: 10.5x ↗
8	Serie 98.9	8	Serie 97.1
	Total 198.0		Total 295.1

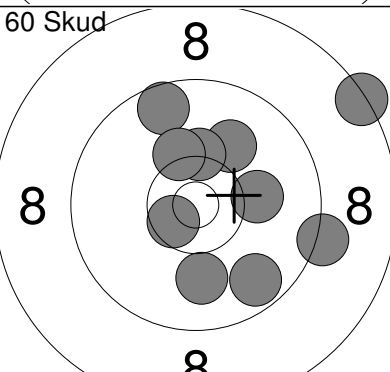
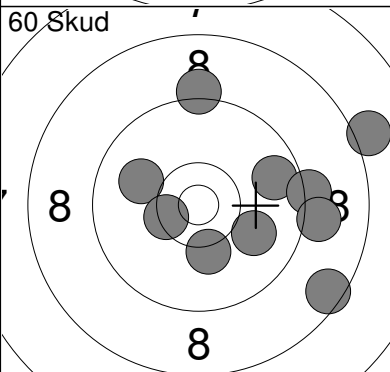

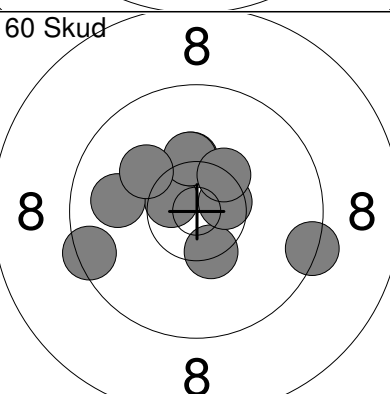
60 Skud 	31: 10.6x ↘ 32: 10.0 ↗ 33: 9.2 → 34: 10.3 ↑ 35: 10.1 → 36: 9.6 ↗ 37: 9.7 ↘ 38: 10.0 ↘ 39: 8.4 → 40: 10.2 ↑	60 Skud 	41: 10.2 ↓ 42: 10.0 ↗ 43: 9.7 → 44: 10.4x ← 45: 10.0 ↘ 46: 9.2 ↑ 47: 8.1 → 48: 9.2 → 49: 8.5 ↘ 50: 9.1 →
8	Serie 98.1	8	Serie 94.4
	Total 393.2		Total 487.6

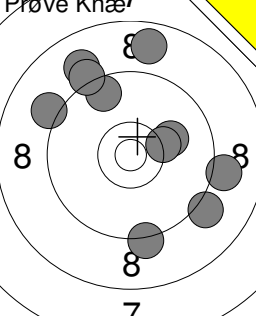
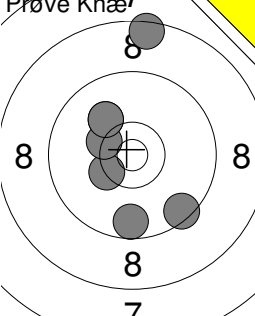
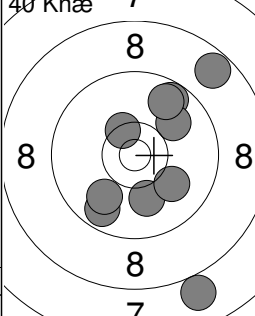
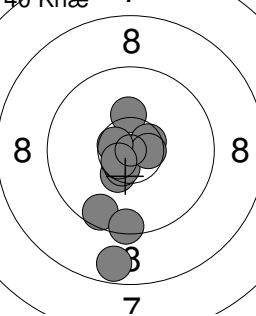
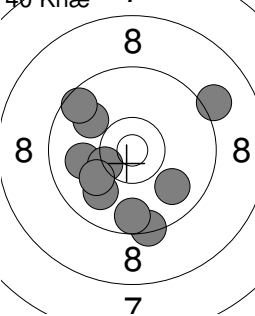
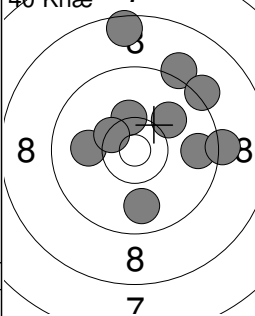
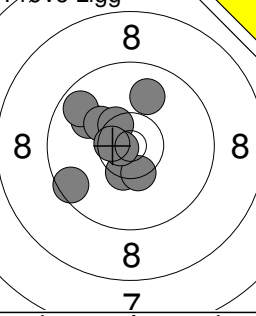
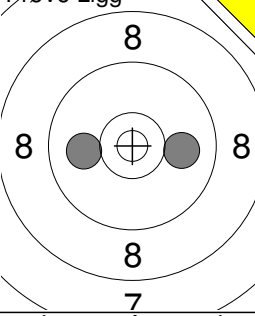
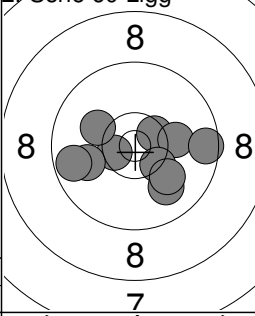
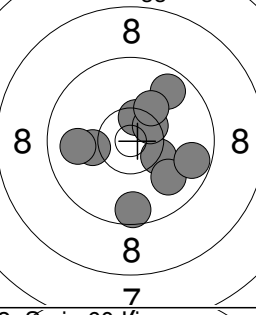
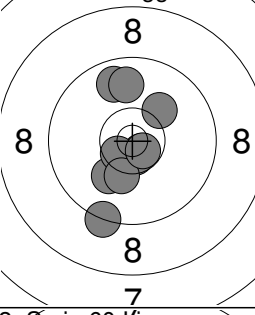
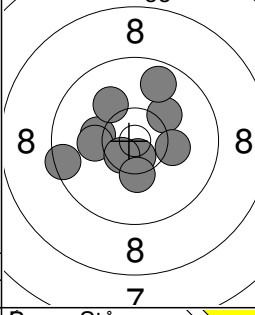
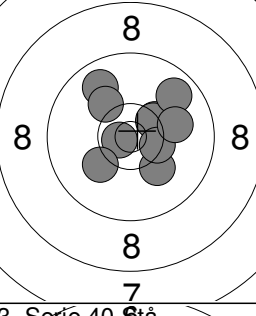
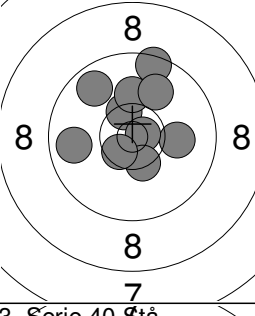
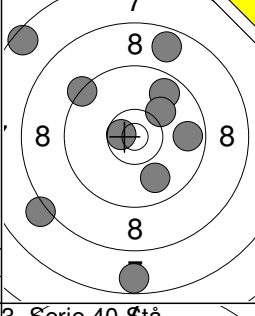
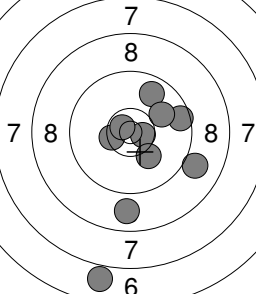
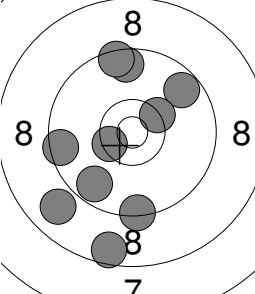
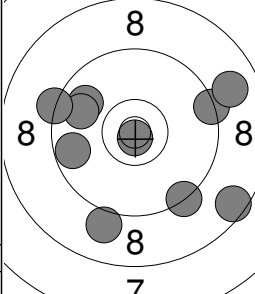
60 Skud 	51: 9.4 → 52: 10.4x ↘ 53: 10.6x ↗ 54: 9.9 ← 55: 10.6x → 56: 10.3 ↑ 57: 9.5 ← 58: 10.3 ↑ 59: 10.4x ↗ 60: 10.1 ↗		
8	Serie 101.5		
	Total 589.1		

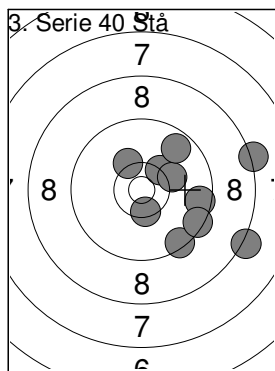
 <p style="text-align: center;">Prøve Knæl</p>	<p>1: 9.1 ↖ 2: 10.1 → 3: 9.6 ↗ 4: 9.0 ↗ 5: 9.2 ↗ 6: 9.1 ↘ 7: 10.3 → 8: 9.1 → 9: 9.2 ↘ 10: 8.8 ↗</p> <p>Serie 91.0 Total 0.0</p>	 <p style="text-align: center;">Prøve Knæl</p>	<p>11: 10.1 ↗ 12: 10.3x ↖ 13: 10.3x ↗ 14: 9.6 ↘ 15: 10.1 ↗ 16: 8.5 ↗ 17: 9.5 ↗</p> <p>Serie 66.0 Total 0.0</p>	 <p style="text-align: center;">40 Knæ</p>	<p>1: 10.1 ↘ 2: 8.7 ↗ 3: 9.7 ↗ 4: 10.0 ↗ 5: 10.4x ↗ 6: 9.7 ↘ 7: 9.7 ↘ 8: 10.0 ↘ 9: 9.9 ↘ 10: 8.0 ↘</p> <p>Serie 92.0 Total 92.0</p>
 <p style="text-align: center;">40 Knæ</p>	<p>11: 9.6 ↘ 12: 8.7 ↘ 13: 10.3 ↗ 14: 10.6x ↗ 15: 9.4 ↘ 16: 10.4x ↘ 17: 10.6x ↘ 18: 10.6x ↗ 19: 10.6x ↗ 20: 10.6x ↖</p> <p>Serie 96.0 Total 188.0</p>	 <p style="text-align: center;">40 Knæ</p>	<p>21: 9.9 ↗ 22: 10.0 ↖ 23: 9.9 ↖ 24: 9.4 ↘ 25: 9.7 ↘ 26: 10.3x ↖ 27: 10.1 ↖ 28: 9.6 ↖ 29: 9.9 ↗ 30: 9.1 ↗</p> <p>Serie 93.0 Total 281.0</p>	 <p style="text-align: center;">40 Knæ</p>	<p>31: 10.1 ↗ 32: 8.5 ↗ 33: 9.2 ↗ 34: 10.0 ↖ 35: 10.3x ↗ 36: 10.4x ↗ 37: 9.7 → 38: 9.8 ↘ 39: 9.2 → 40: 9.2 ↗</p> <p>Serie 93.0 Total 374.0</p>
 <p style="text-align: center;">Prøve Ligg</p>	<p>1: 10.0 ↖ 2: 9.7 ↖ 3: 9.9 ↗ 4: 10.2 ↗ 5: 10.4x ↗ 6: 10.4x ↘ 7: 10.4x ↘ 8: 9.5 ↖ 9: 10.8x ↖ 10: 10.6x ↖</p> <p>Serie 97.0 Total 374.0</p>	 <p style="text-align: center;">Prøve Ligg</p>	<p>11: 10.0 → 12: 10.0 ↖</p> <p>Serie 20.0 Total 374.0</p>	 <p style="text-align: center;">2. Serie 60 Ligg</p>	<p>1: 10.5x ↗ 2: 10.1 → 3: 10.5x ↖ 4: 10.0 ↖ 5: 9.7 ↖ 6: 10.1 ↗ 7: 9.9 ↘ 8: 10.4x ↘ 9: 9.6 ↘ 10: 10.1 ↗</p> <p>Serie 97.0 Total 471.0</p>
 <p style="text-align: center;">2. Serie 60 Ligg</p>	<p>11: 10.3x ↖ 12: 9.6 ↘ 13: 9.9 ↘ 14: 10.5x ↗ 15: 10.2 ↖ 16: 9.7 ↗ 17: 10.5x ↗ 18: 9.9 ↖ 19: 9.7 ↗ 20: 10.2 ↗</p> <p>Serie 95.0 Total 566.0</p>	 <p style="text-align: center;">2. Serie 60 Ligg</p>	<p>21: 9.8 ↗ 22: 9.8 ↗ 23: 10.2 ↗ 24: 9.3 ↘ 25: 10.7x ↘ 26: 10.1 ↖ 27: 10.6x ↘ 28: 10.6x ↘ 29: 10.2 ↘ 30: 10.7x ↘</p> <p>Serie 97.0 Total 663.0</p>	 <p style="text-align: center;">2. Serie 60 Ligg</p>	<p>31: 10.2 ↗ 32: 9.7 ↗ 33: 10.2 ↖ 34: 10.2 ↖ 35: 10.2 ↖ 36: 10.6x ↘ 37: 9.5 ↖ 38: 10.6x ↖ 39: 10.3 ↘ 40: 10.1 ↗</p> <p>Serie 98.0 Total 761.0</p>
 <p style="text-align: center;">2. Serie 60 Ligg</p>	<p>41: 10.7x ↖ 42: 10.1 ↖ 43: 10.1 ↖ 44: 9.8 ↗ 45: 10.1 ↗ 46: 10.4x ↗ 47: 10.4x ↗ 48: 10.4x ↗ 49: 9.8 ↗ 50: 10.0 ↗</p> <p>Serie 98.0 Total 859.0</p>	 <p style="text-align: center;">2. Serie 60 Ligg</p>	<p>51: 10.1 → 52: 10.4x ↖ 53: 9.8 ↖ 54: 10.7x ↗ 55: 10.1 ↗ 56: 10.4x ↘ 57: 9.5 ↗ 58: 9.7 ↗ 59: 10.6x ↗ 60: 10.0 ↗</p> <p>Serie 97.0 Total 956.0</p>	 <p style="text-align: center;">Prøve Stå</p>	<p>1: 7.5 ↗ 2: 9.3 ↗ 3: 8.1 ↖ 4: 8.7 ↗ 5: 7.7 ↘ 6: 10.6x ↖ 7: 9.7 ↗ 8: 9.9 ↘ 9: 9.7 ↘ 10: 10.1 ↗</p> <p>Serie 86.0 Total 956.0</p>
 <p style="text-align: center;">3. Serie 40 Stå</p>	<p>1: 9.8 ↗ 2: 9.6 → 3: 10.4x ↖ 4: 10.6x ↘ 5: 6.9 ↘ 6: 8.8 ↘ 7: 9.0 ↗ 8: 10.7x ↗ 9: 10.0 ↗ 10: 10.2 ↗</p> <p>Serie 91.0 Total 1047.0</p>	 <p style="text-align: center;">3. Serie 40 Stå</p>	<p>11: 9.5 ↖ 12: 8.9 ↖ 13: 8.6 ↘ 14: 10.4x ↖ 15: 9.7 ↖ 16: 9.6 ↗ 17: 10.4x ↗ 18: 9.7 ↘ 19: 9.5 ↗ 20: 9.4 ↘</p> <p>Serie 90.0 Total 1137.0</p>	 <p style="text-align: center;">3. Serie 40 Stå</p>	<p>21: 9.4 ↗ 22: 9.8 ↗ 23: 9.3 ↘ 24: 9.8 ↘ 25: 10.8x ↘ 26: 8.9 ↗ 27: 9.3 ↖ 28: 9.0 ↘ 29: 9.7 ↖ 30: 8.6 ↘</p> <p>Serie 89.0 Total 1226.0</p>

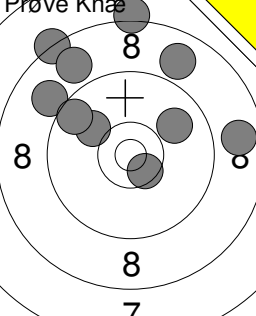
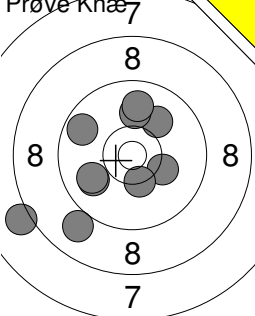
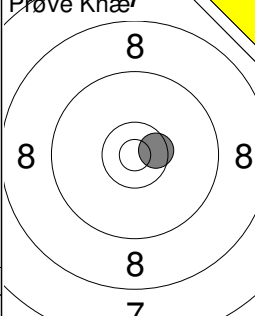
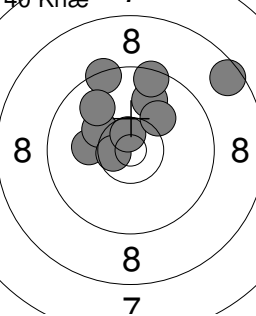
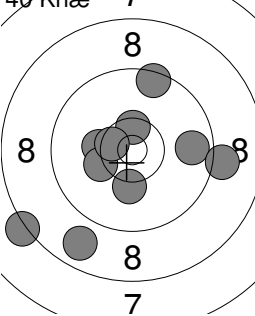
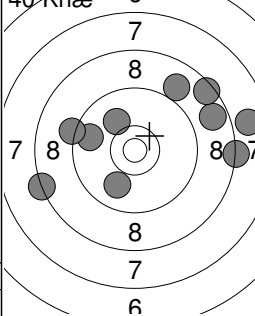
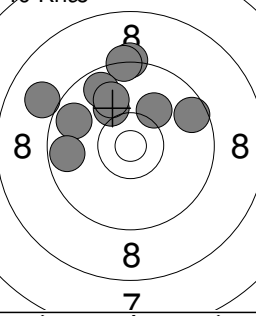
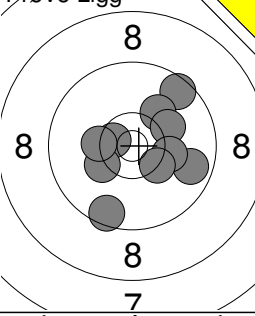
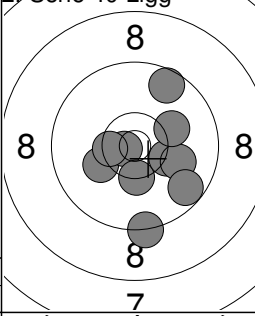
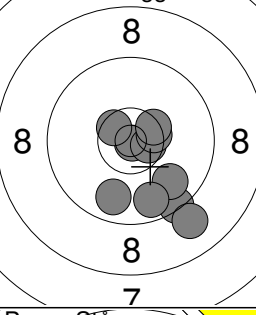
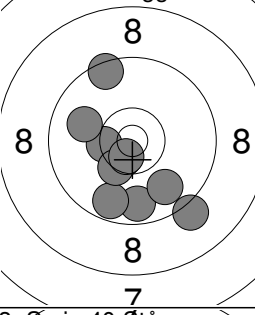
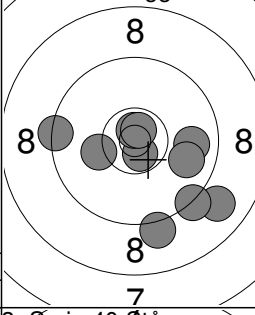
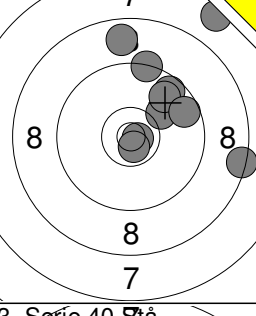
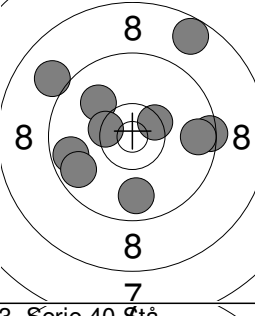
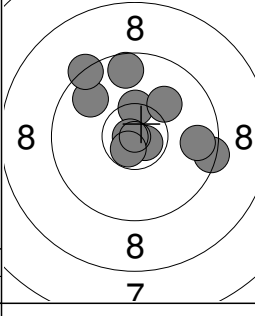
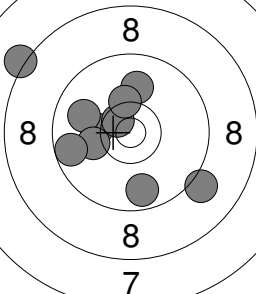
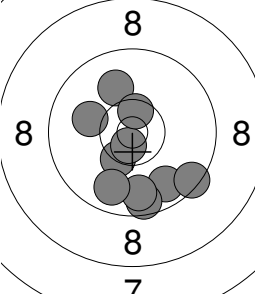

31:	10.4x	↓
32:	10.3x	↗
33:	10.3	↗
34:	8.2	→
35:	8.2	↘
36:	9.6	→
37:	10.2	↗
38:	9.4	↘
39:	9.7	↗
40:	9.5	↘
Serie	92.0	
Total	1318.0	

 <p style="text-align:center;">Prøve Knæ</p>	<p>1: 10.0 ↗ 2: 8.3 ↗ 3: 8.2 ↗ 4: 8.9 ↗ 5: 9.0 ↗ 6: 8.8 ↗ 7: 9.6 ↗ 8: 8.9 ↗ 9: 9.9 ↗ 10: 10.5x ↘</p> <p>Serie 87.0 Total 0.0</p>	 <p style="text-align:center;">Prøve Knæ</p>	<p>11: 8.1 ↘ 12: 9.9 ↘ 13: 9.7 ↘ 14: 10.0 ↗ 15: 9.9 ↘ 16: 10.0 ↗ 17: 10.2 ↘ 18: 10.3x ↘ 19: 9.0 ↘ 20: 9.9 ↗</p> <p>Serie 93.0 Total 0.0</p>	 <p style="text-align:center;">Prøve Knæ</p>	<p>21: 10.5x →</p> <p>Serie 10.0 Total 0.0</p>
 <p style="text-align:center;">40 Knæ</p>	<p>1: 9.4 ↗ 2: 10.1 ↗ 3: 9.9 ↗ 4: 10.2 ↗ 5: 9.9 ↗ 6: 10.6x ↗ 7: 10.6x ↗ 8: 8.6 ↗ 9: 10.1 ↗ 10: 9.5 ↗</p> <p>Serie 94.0 Total 94.0</p>	 <p style="text-align:center;">40 Knæ</p>	<p>11: 10.5x ↗ 12: 9.5 ↗ 13: 10.3 ↗ 14: 9.8 ↗ 15: 10.3 ↗ 16: 9.1 ↗ 17: 8.8 ↗ 18: 10.2 ↘ 19: 8.2 ↘ 20: 10.5x ↗</p> <p>Serie 93.0 Total 187.0</p>	 <p style="text-align:center;">40 Knæ</p>	<p>21: 8.7 → 22: 8.3 → 23: 8.5 → 24: 9.9 ↘ 25: 8.3 ↗ 26: 9.7 ↗ 27: 7.9 → 28: 9.0 ↗ 29: 9.2 ↗ 30: 10.0 ↗</p> <p>Serie 85.0 Total 272.0</p>
 <p style="text-align:center;">40 Knæ</p>	<p>31: 9.3 ↗ 32: 10.1 ↗ 33: 9.3 ↗ 34: 9.6 ↗ 35: 9.7 ↗ 36: 9.7 ↗ 37: 9.0 ↗ 38: 9.7 ↗ 39: 10.0 ↗ 40: 10.1 ↗</p> <p>Serie 93.0 Total 365.0</p>	 <p style="text-align:center;">Prøve Ligg</p>	<p>1: 9.6 ↗ 2: 10.1 ↗ 3: 10.2 ↗ 4: 9.5 ↘ 5: 9.7 ↘ 6: 10.6x ↗ 7: 10.2 ↗ 8: 10.3x ↘ 9: 10.2 ↗ 10: 10.3x ↗</p> <p>Serie 97.0 Total 365.0</p>	 <p style="text-align:center;">2. Serie 40 Ligg</p>	<p>1: 10.2 ↗ 2: 9.3 ↘ 3: 9.6 ↗ 4: 10.7x ↗ 5: 10.3x ↘ 6: 10.3 ↘ 7: 10.5x ↗ 8: 10.0 ↘ 9: 9.7 ↘ 10: 10.1 ↘</p> <p>Serie 97.0 Total 462.0</p>
 <p style="text-align:center;">2. Serie 40 Ligg</p>	<p>11: 9.8 ↘ 12: 10.9x ↘ 13: 9.4 ↘ 14: 10.6x ↗ 15: 10.5x ↗ 16: 10.4x ↗ 17: 9.0 ↘ 18: 10.5x ↗ 19: 9.8 ↘ 20: 9.7 ↘</p> <p>Serie 95.0 Total 557.0</p>	 <p style="text-align:center;">2. Serie 40 Ligg</p>	<p>21: 10.6x ↗ 22: 10.4x ↗ 23: 9.7 ↘ 24: 9.8 ↘ 25: 9.7 ↘ 26: 10.3x ↗ 27: 10.6x ↗ 28: 10.0 ↗ 29: 9.1 ↘ 30: 9.5 ↗</p> <p>Serie 95.0 Total 652.0</p>	 <p style="text-align:center;">2. Serie 40 Ligg</p>	<p>31: 10.2 ↗ 32: 9.8 ↗ 33: 10.7x ↗ 34: 9.9 ↗ 35: 10.7x ↗ 36: 8.9 ↘ 37: 9.1 ↘ 38: 9.3 ↘ 39: 10.7x ↗ 40: 9.4 ↗</p> <p>Serie 93.0 Total 745.0</p>
 <p style="text-align:center;">Prøve Stå</p>	<p>1: 10.8x → 2: 9.3 ↗ 3: 8.8 ↗ 4: 8.4 → 5: 10.7x ↘ 6: 10.1 ↗ 7: 9.6 ↗ 8: 7.6 ↗ 9: 9.8 ↗ 10: 9.6 ↗</p> <p>Serie 89.0 Total 745.0</p>	 <p style="text-align:center;">3. Serie 40 Stå</p>	<p>1: 10.0 ↗ 2: 10.4x ↗ 3: 9.4 → 4: 9.7 → 5: 9.8 ↘ 6: 9.7 ↗ 7: 8.7 ↗ 8: 10.4x ↗ 9: 9.7 ↗ 10: 9.0 ↗</p> <p>Serie 92.0 Total 837.0</p>	 <p style="text-align:center;">3. Serie 40 Stå</p>	<p>11: 10.4x ↗ 12: 10.7x ↗ 13: 9.6 ↗ 14: 9.4 → 15: 10.9x ↗ 16: 9.8 ↗ 17: 10.1 ↗ 18: 10.7x ↗ 19: 9.3 ↗ 20: 9.7 →</p> <p>Serie 95.0 Total 932.0</p>
 <p style="text-align:center;">3. Serie 40 Stå</p>	<p>21: 8.2 ↗ 22: 10.2 ↗ 23: 9.9 ↗ 24: 10.0 ↗ 25: 10.6x ↗ 26: 10.3 ↗ 27: 10.1 ↗ 28: 9.1 ↗ 29: 9.7 ↗ 30: 9.7 ↗</p> <p>Serie 94.0 Total 1026.0</p>	 <p style="text-align:center;">3. Serie 40 Stå</p>	<p>31: 10.0 ↗ 32: 9.8 ↗ 33: 9.6 ↗ 34: 10.3x ↗ 35: 10.7x ↗ 36: 10.5x ↗ 37: 10.1 ↗ 38: 9.4 ↗ 39: 9.8 ↗ 40: 9.8 ↗</p> <p>Serie 95.0 Total 1121.0</p>	 <p style="text-align:center;">3. Serie 40 Stå</p>	<p>Serie 95.0 Total 932.0</p>

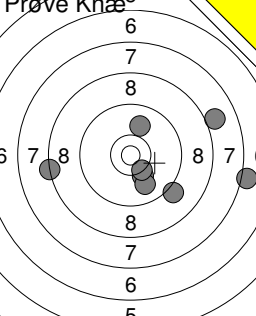
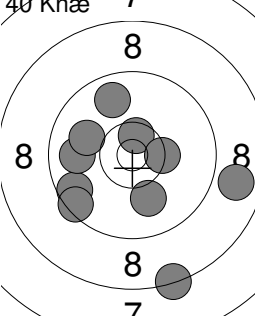
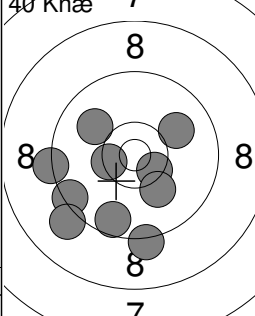
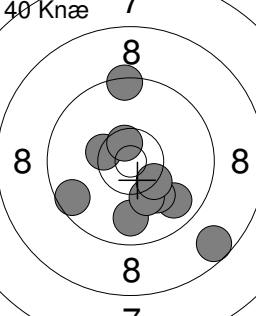
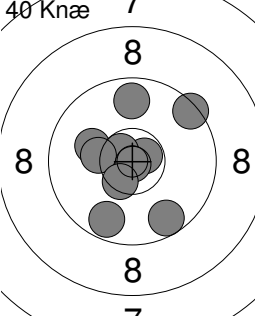
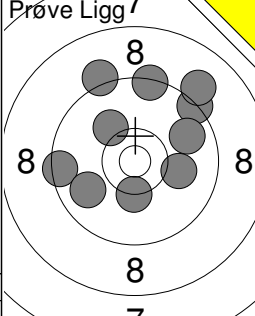
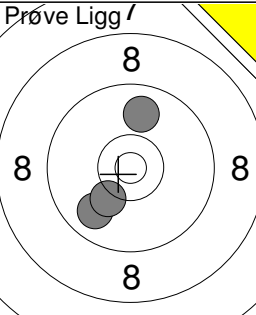
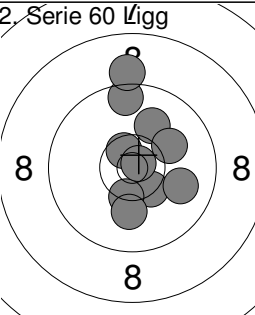
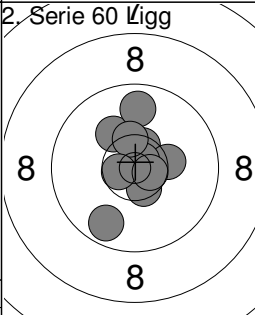
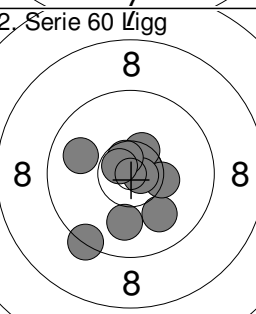
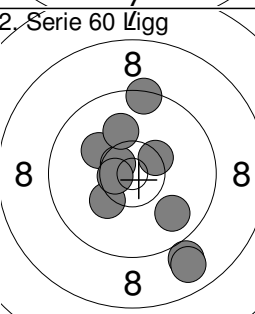
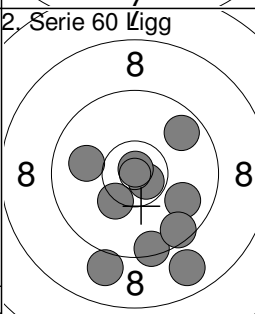
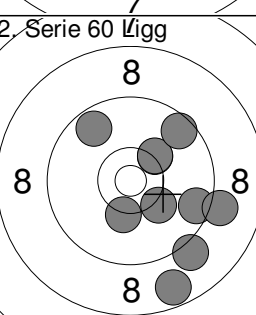
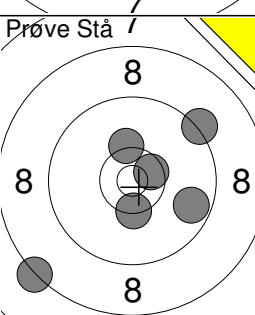
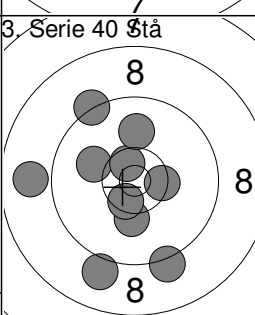
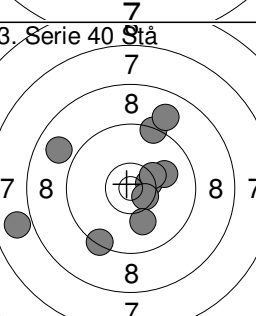
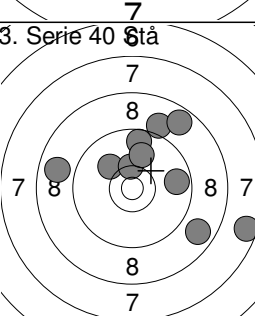
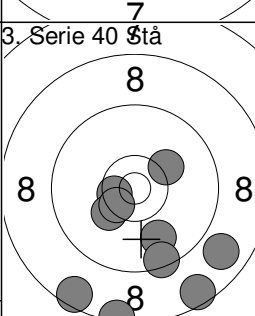
	<p>1: 7.1 →</p> <p>2: 8.0 →</p> <p>3: 8.3 ←</p> <p>4: 10.2 ↓</p> <p>5: 9.2 ↓</p> <p>6: 9.9 ↓</p> <p>7: 10.3x ↓</p> <p>8: 10.0 ↑</p>	<p>40 Knæ /</p> 	<p>1: 9.6 ←</p> <p>2: 9.9 ←</p> <p>3: 8.3 ↓</p> <p>4: 9.8 ↑</p> <p>5: 10.6x ↑</p> <p>6: 10.4x ↑</p> <p>7: 10.0 →</p> <p>8: 9.5 ↓</p> <p>9: 10.0 ↓</p> <p>10: 8.8 →</p>	<p>40 Knæ /</p> 	<p>11: 10.0 ↗</p> <p>12: 10.5x ↘</p> <p>13: 9.4 ←</p> <p>14: 9.3 ←</p> <p>15: 10.0 ↗</p> <p>16: 10.1 ↗</p> <p>17: 10.4x ←</p> <p>18: 9.1 ↘</p> <p>19: 9.6 ↘</p> <p>20: 9.2 ↓</p>
	Serie 71.0		Serie 92.0		Serie 95.0
	Total 0.0	7	Total 92.0	7	Total 187.0
	<p>21: 9.8 ↓</p> <p>22: 10.1 ↓</p> <p>23: 8.6 ↓</p> <p>24: 9.6 ←</p> <p>25: 9.8 ↓</p> <p>26: 9.4 ↑</p> <p>27: 10.2 ↓</p> <p>28: 10.3x ↓</p> <p>29: 10.4x ↑</p> <p>30: 10.6x ↑</p>	<p>40 Knæ /</p> 	<p>31: 10.1 ↗</p> <p>32: 9.7 ↘</p> <p>33: 10.7x ↘</p> <p>34: 9.8 ↑</p> <p>35: 10.7x ↑</p> <p>36: 9.7 ↘</p> <p>37: 10.3 ←</p> <p>38: 9.5 ↓</p> <p>39: 10.9x ↓</p> <p>40: 10.5x ↓</p>	<p>Prøve Ligg /</p> 	<p>1: 9.4 ↑</p> <p>2: 9.3 ↗</p> <p>3: 9.0 ↗</p> <p>4: 9.8 ↗</p> <p>5: 10.1 ↗</p> <p>6: 10.3x ↓</p> <p>7: 9.2 ↗</p> <p>8: 9.5 ←</p> <p>9: 9.9 ←</p> <p>10: 10.1 →</p>
	Serie 94.0		Serie 96.0		Serie 93.0
	Total 281.0	7	Total 377.0	7	Total 377.0
	<p>11: 9.9 ↘</p> <p>12: 9.9 ↑</p> <p>13: 10.2 ↓</p>	<p>2. Serie 60 Ligg</p> 	<p>1: 10.0 ↑</p> <p>2: 10.4x ↓</p> <p>3: 10.4x ↓</p> <p>4: 10.6x ↓</p> <p>5: 10.1 →</p> <p>6: 9.6 ↑</p> <p>7: 9.1 ↑</p> <p>8: 9.9 ↓</p> <p>9: 10.8x ↓</p> <p>10: 10.1 ↓</p>	<p>2. Serie 60 Ligg</p> 	<p>11: 10.5x ↑</p> <p>12: 10.2 ↗</p> <p>13: 9.7 ↘</p> <p>14: 10.3x →</p> <p>15: 10.7x ↗</p> <p>16: 9.8 ↑</p> <p>17: 10.4x ↑</p> <p>18: 10.5x ↓</p> <p>19: 10.6x ←</p> <p>20: 10.6x →</p>
	Serie 28.0		Serie 97.0		Serie 98.0
	Total 377.0	7	Total 474.0	7	Total 572.0
	<p>21: 9.9 ↘</p> <p>22: 10.0 ↓</p> <p>23: 10.7x →</p> <p>24: 10.0 ↓</p> <p>25: 9.3 ↓</p> <p>26: 10.3x ↓</p> <p>27: 10.4x ↑</p> <p>28: 10.8x →</p> <p>29: 10.6x ↑</p> <p>30: 10.7x ↑</p>	<p>2. Serie 60 Ligg</p> 	<p>31: 9.0 ↓</p> <p>32: 10.1 ↘</p> <p>33: 10.6x ↗</p> <p>34: 8.8 ↓</p> <p>35: 10.2 ↘</p> <p>36: 10.6x ←</p> <p>37: 10.1 ↑</p> <p>38: 9.8 ↘</p> <p>39: 10.4x ↗</p> <p>40: 9.4 ↑</p>	<p>2. Serie 60 Ligg</p> 	<p>41: 10.3x ↘</p> <p>42: 10.0 ←</p> <p>43: 9.0 ↘</p> <p>44: 9.7 ↗</p> <p>45: 9.9 ↘</p> <p>46: 8.8 ↘</p> <p>47: 10.7x ↘</p> <p>48: 9.4 ↘</p> <p>49: 9.6 ↘</p> <p>50: 10.9x ↑</p>
	Serie 98.0		Serie 95.0		Serie 93.0
	Total 670.0	7	Total 765.0	7	Total 858.0
	<p>51: 9.6 →</p> <p>52: 10.3 ↓</p> <p>53: 10.3 ↓</p> <p>54: 9.1 →</p> <p>55: 8.7 ↓</p> <p>56: 9.1 ↓</p> <p>57: 9.7 ↗</p> <p>58: 10.3 ↗</p> <p>59: 9.6 ↗</p> <p>60: 10.2 ↓</p>	<p>Prøve Stå /</p> 	<p>1: 10.5x →</p> <p>2: 8.3 ↘</p> <p>3: 9.7 ↘</p> <p>4: 9.2 ↗</p> <p>5: 10.3 ↗</p> <p>6: 10.3x ↓</p>	<p>3. Serie 40 Stå</p> 	<p>1: 8.9 ←</p> <p>2: 10.1 ↗</p> <p>3: 9.2 ↘</p> <p>4: 10.6x ↗</p> <p>5: 9.3 ↗</p> <p>6: 10.2 ↓</p> <p>7: 9.0 ↘</p> <p>8: 10.5x ↘</p> <p>9: 10.4x →</p> <p>10: 10.0 ↑</p>
	Serie 93.0		Serie 56.0		Serie 95.0
	Total 951.0	7	Total 951.0	7	Total 1046.0
	<p>11: 7.9 ←</p> <p>12: 9.4 ↑</p> <p>13: 8.9 ↑</p> <p>14: 9.4 ↗</p> <p>15: 10.5x ↗</p> <p>16: 10.0 →</p> <p>17: 10.3x →</p> <p>18: 10.5x ↘</p> <p>19: 8.9 ↘</p> <p>20: 10.0 ↘</p>	<p>3. Serie 40 Stå</p> 	<p>21: 9.6 ↑</p> <p>22: 10.1 ↗</p> <p>23: 9.1 ↗</p> <p>24: 8.7 ↗</p> <p>25: 8.8 ↗</p> <p>26: 10.4x ↑</p> <p>27: 9.7 →</p> <p>28: 8.8 ↘</p> <p>29: 10.0 ↑</p> <p>30: 7.6 ↘</p>	<p>3. Serie 40 Stå</p> 	<p>31: 8.5 ↘</p> <p>32: 10.5x ←</p> <p>33: 8.4 ↘</p> <p>34: 10.2 ↗</p> <p>35: 9.9 ↘</p> <p>36: 8.6 ↘</p> <p>37: 10.3 ↘</p> <p>38: 9.5 ↘</p> <p>39: 10.5x ↘</p> <p>40: 8.9 ↘</p>
	Serie 91.0		Serie 88.0		Serie 90.0
	Total 1137.0	6	Total 1225.0	7	Total 1315.0

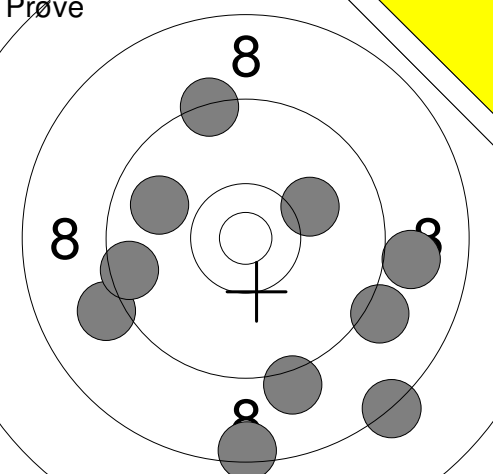
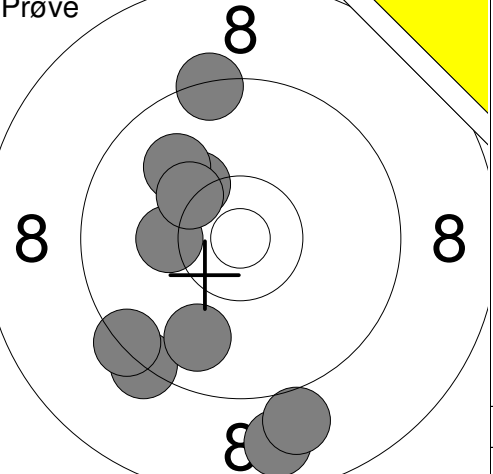
Prøve 	1: 9.3 ↗ 2: 9.1 ↘ 3: 9.1 ↖ 4: 10.1 → 5: 8.3 ↘ 6: 9.1 ↘ 7: 9.9 ↗ 8: 8.4 ↘ 9: 9.0 → 10: 9.5 ← <hr/> Serie 91.8 Total 0.0	Prøve 	11: 10.2 ↗ 12: 10.2 ← 13: 9.3 ↘ 14: 10.0 ↗ 15: 8.8 ↘ 16: 9.0 ↘ 17: 9.8 ↘ 18: 9.3 ↗ 19: 10.3 ↗ 20: 9.4 ↘ <hr/> Serie 96.3 Total 0.0
---	---	---	---

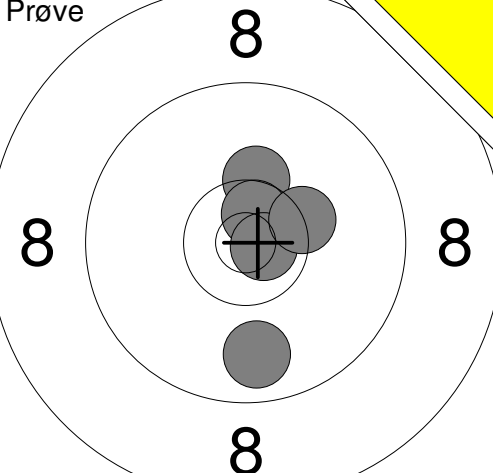
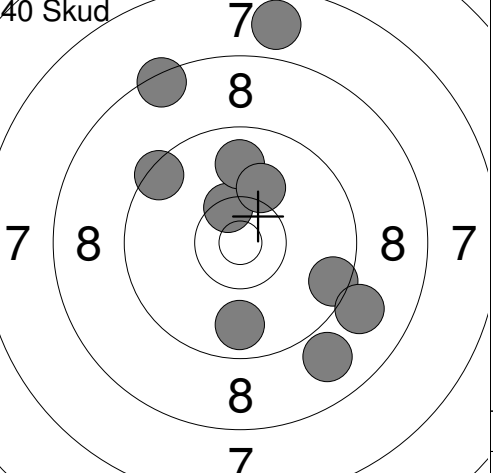
Prøve 	21: 10.3x ↗ 22: 10.6x ↗ 23: 9.8 ↘ 24: 10.8x → 25: 10.3x → <hr/> Serie 51.8 Total 0.0	40 Skud 	1: 9.5 → 2: 9.5 ↗ 3: 9.8 ↘ 4: 9.0 ↘ 5: 8.9 ↘ 6: 10.4x ↗ 7: 8.4 ↗ 8: 7.8 ↗ 9: 9.8 ↗ 10: 10.1 ↗ <hr/> Serie 93.2 Total 93.2
--	--	--	--

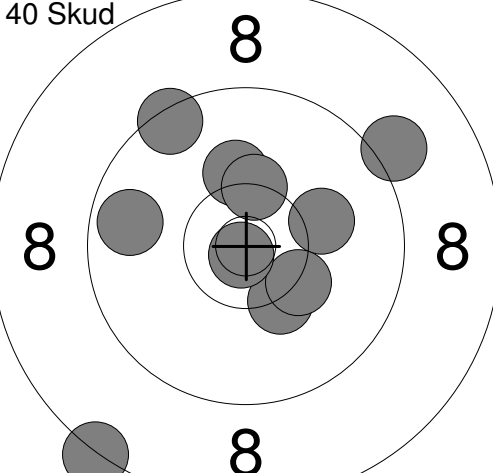
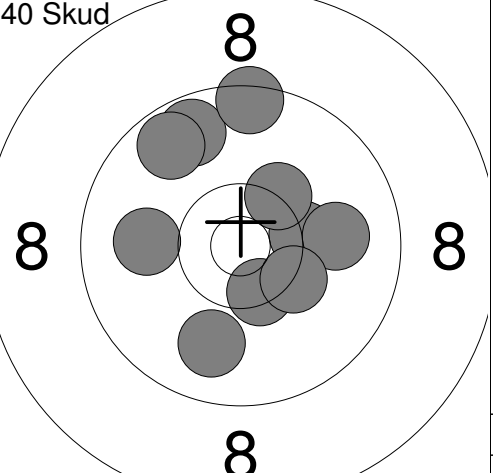
40 Skud 	11: 8.3 ↘ 12: 10.1 → 13: 9.4 ↗ 14: 9.7 ← 15: 10.2 ↗ 16: 10.3 ↘ 17: 10.3 ↘ 18: 10.3x ↗ 19: 9.1 → 20: 10.8x ↘ <hr/> Serie 98.5 Total 191.7	40 Skud 	21: 10.3x → 22: 9.7 ↗ 23: 9.7 ↗ 24: 9.9 ↘ 25: 10.0 → 26: 10.0 ← 27: 10.4x ↘ 28: 10.3x ↗ 29: 10.3x ↘ 30: 9.4 ↗ <hr/> Serie 100.0 Total 291.7
---	---	---	--

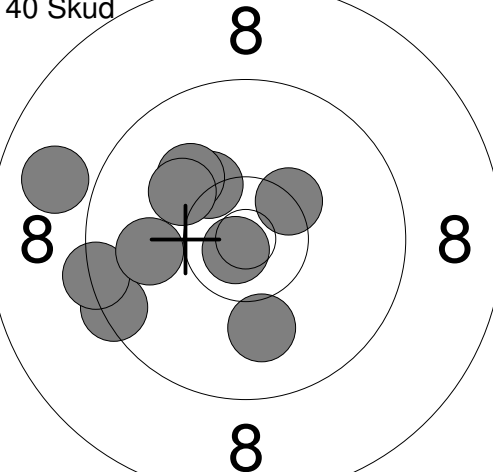
40 Skud 	31: 10.3 ↗ 32: 10.1 ↗ 33: 9.4 ← 34: 9.4 ← 35: 10.1 ↗ 36: 10.0 ↘ 37: 10.0 ← 38: 10.4x ↗ 39: 10.8x ↘ 40: 8.9 ← <hr/> Serie 99.4 Total 391.1		
---	--	--	--

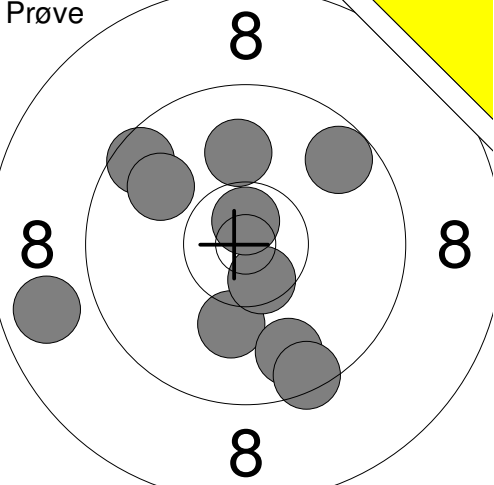
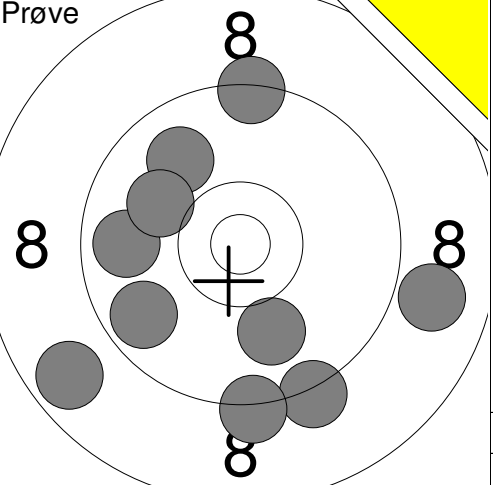
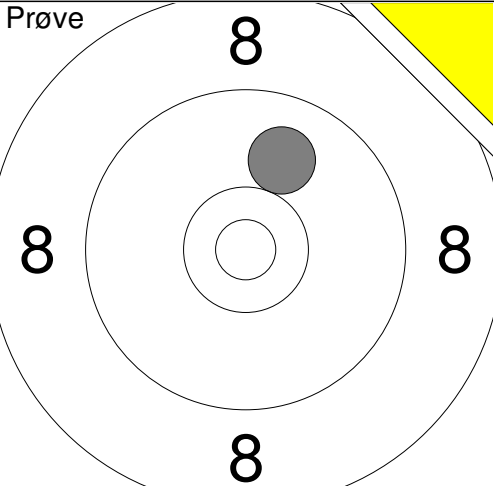
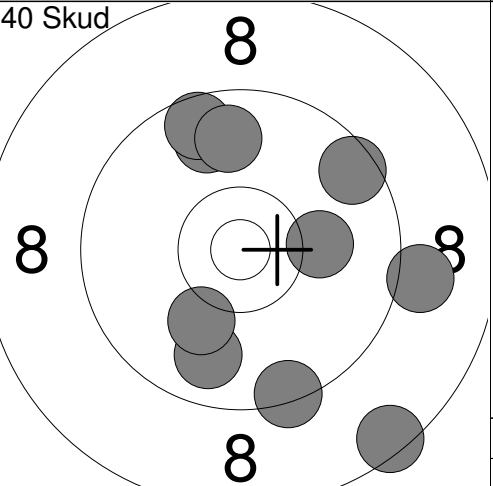
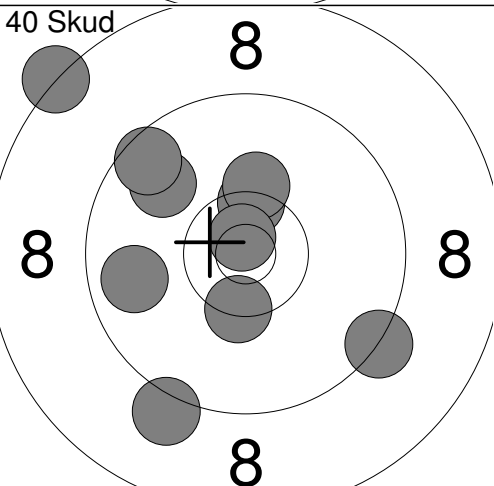
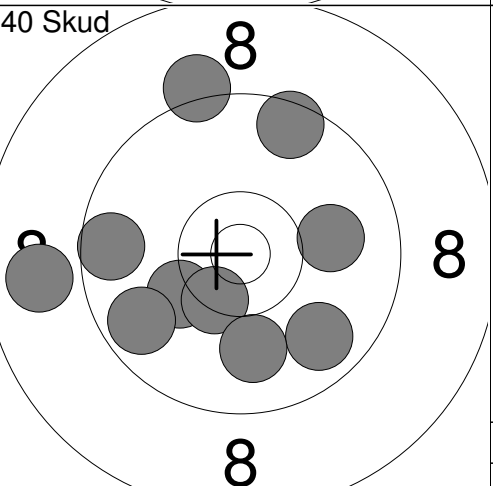
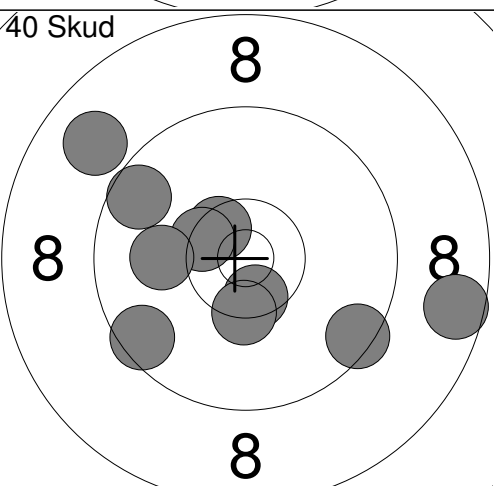
Hold	Skive	Knud Jensen	
3	3		
50m		Frederikshavn Skyttekreds	
31.05.2015		DSU stævne 2015	Aalborg Skyttekreds
Prøve		1: 10.1 ↓ 2: 10.0 ↑ 3: 9.6 ↗ 4: 9.7 ↗ 5: 9.8 ↓ 6: 10.5x ↓ 7: 9.9 ↗ 8: 9.5 ↓ 9: 8.8 ← 10: 10.7x ↑ Serie 98.6 Total 0.0	Prøve  11: 8.7 ↙ 12: 9.8 ← 13: 9.9 ↗ 14: 10.0 ↓ 15: 8.9 → 16: 9.4 ↑ 17: 10.0 ← 18: 9.7 ↙ 19: 9.2 ↓ 20: 9.2 ↓ Serie 94.8 Total 0.0
Prøve		21: 10.0 ↑ Serie 10.0 Total 0.0	40 Skud  1: 9.1 → 2: 9.8 ↑ 3: 9.8 ↓ 4: 8.5 ↓ 5: 9.6 ↗ 6: 9.4 ↓ 7: 10.1 → 8: 10.1 ↓ 9: 9.8 ↑ 10: 9.5 ↗ Serie 95.7 Total 95.7
40 Skud		11: 9.3 ↘ 12: 9.1 ↓ 13: 9.8 ↗ 14: 8.3 ↗ 15: 9.8 ← 16: 10.4x ↑ 17: 10.4x ↓ 18: 10.2 ↑ 19: 10.8x ↑ 20: 9.6 ↗ Serie 97.7 Total 193.4	40 Skud  21: 9.2 ↑ 22: 10.0 → 23: 8.9 ← 24: 10.2 ↙ 25: 9.6 ← 26: 10.4x ↓ 27: 9.8 ↘ 28: 9.7 ↙ 29: 9.5 ↑ 30: 10.0 ↓ Serie 97.3 Total 290.7
40 Skud		31: 10.5x ↗ 32: 10.4x ↖ 33: 9.5 ← 34: 9.6 ↗ 35: 10.5x ↓ 36: 9.5 ↓ 37: 8.6 → 38: 10.4x ↓ 39: 8.9 ↗ 40: 10.0 ← Serie 97.9 Total 388.6	

<p>Prøve</p>	<p>1: 8.0 ↗ 2: 9.6 ↗ 3: 9.7 ↗ 4: 8.9 ↗ 5: 8.8 → 6: 8.5 ← 7: 8.4 ← 8: 9.7 ↗ 9: 10.1 ↓ 10: 9.8 →</p> <table border="1" style="width:100%; border-collapse: collapse;"> <tr><td>Serie</td><td style="text-align: right;">91.5</td></tr> <tr><td>Total</td><td style="text-align: right;">0.0</td></tr> </table>	Serie	91.5	Total	0.0	<p>Prøve</p>	<p>11: 10.5x ↗ 12: 10.0 → 13: 10.6x →</p> <table border="1" style="width:100%; border-collapse: collapse;"> <tr><td>Serie</td><td style="text-align: right;">31.1</td></tr> <tr><td>Total</td><td style="text-align: right;">0.0</td></tr> </table>	Serie	31.1	Total	0.0
Serie	91.5										
Total	0.0										
Serie	31.1										
Total	0.0										

<p>40 Skud</p>	<p>1: 9.6 ↙ 2: 9.9 ↓ 3: 10.5x ↙ 4: 8.9 ↙ 5: 10.9x ↙ 6: 9.6 → 7: 9.8 ↓ 8: 9.8 ↘ 9: 9.9 ← 10: 10.4x ↗</p> <table border="1" style="width:100%; border-collapse: collapse;"> <tr><td>Serie</td><td style="text-align: right;">99.3</td></tr> <tr><td>Total</td><td style="text-align: right;">99.3</td></tr> </table>	Serie	99.3	Total	99.3	<p>40 Skud</p>	<p>11: 9.6 ← 12: 9.5 ← 13: 10.0 ↙ 14: 10.3x ↗ 15: 10.0 ↗ 16: 10.0 ↓ 17: 9.6 ↘ 18: 9.4 ↙ 19: 8.3 ↓ 20: 10.5x ↙</p> <table border="1" style="width:100%; border-collapse: collapse;"> <tr><td>Serie</td><td style="text-align: right;">97.2</td></tr> <tr><td>Total</td><td style="text-align: right;">196.5</td></tr> </table>	Serie	97.2	Total	196.5
Serie	99.3										
Total	99.3										
Serie	97.2										
Total	196.5										

<p>40 Skud</p>	<p>21: 10.0 ↑ 22: 8.2 → 23: 10.6x ↙ 24: 10.2 ↙ 25: 9.3 ↓ 26: 9.5 → 27: 9.2 ↘ 28: 8.9 ↑ 29: 9.7 ↗ 30: 9.2 →</p> <table border="1" style="width:100%; border-collapse: collapse;"> <tr><td>Serie</td><td style="text-align: right;">94.8</td></tr> <tr><td>Total</td><td style="text-align: right;">291.3</td></tr> </table>	Serie	94.8	Total	291.3	<p>40 Skud</p>	<p>31: 9.7 ↗ 32: 9.7 ↙ 33: 10.4x ↙ 34: 9.9 → 35: 10.1 ↓ 36: 10.4x → 37: 10.1 ↓ 38: 10.5x ↘ 39: 10.6x ↙ 40: 9.6 ↑</p> <table border="1" style="width:100%; border-collapse: collapse;"> <tr><td>Serie</td><td style="text-align: right;">101.0</td></tr> <tr><td>Total</td><td style="text-align: right;">392.3</td></tr> </table>	Serie	101.0	Total	392.3
Serie	94.8										
Total	291.3										
Serie	101.0										
Total	392.3										

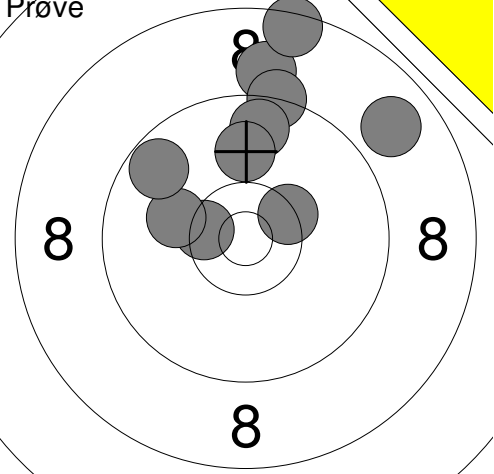
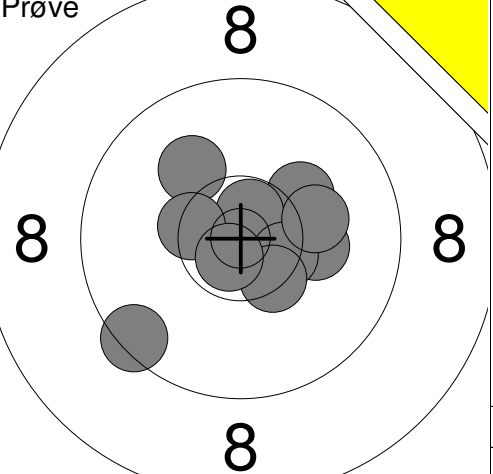
Prøve 	1: 9.0 ↑ 2: 8.5 ↑ 3: 8.8 ↗ 4: 9.3 ↑ 5: 9.7 ↑ 6: 10.0 ↑ 7: 10.4x ↗ 8: 10.5x ← 9: 10.1 ← 10: 9.7 ↖ <hr/> Serie 96.0 Total 0.0	Prøve 	11: 9.4 ↙ 12: 10.2 ↗ 13: 10.7x ↑ 14: 10.2 → 15: 10.5x → 16: 10.2 → 17: 10.4x ↘ 18: 10.1 ↗ 19: 10.4x ← 20: 10.7x ↘ <hr/> Serie 102.8 Total 0.0
---	--	---	--

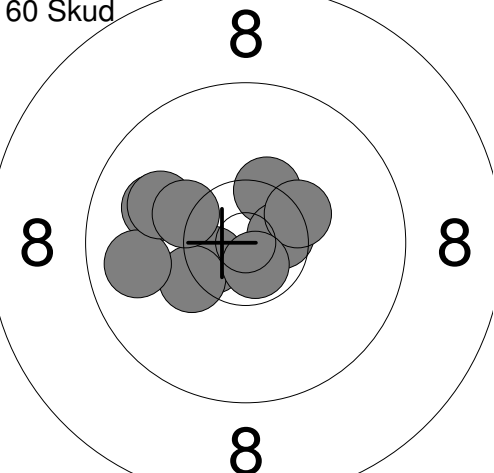
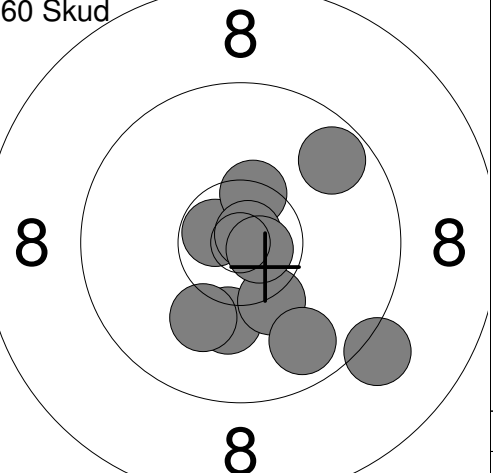
60 Skud 	1: 10.4x ↑ 2: 10.6x ← 3: 10.6x → 4: 10.3 ← 5: 10.3x ↗ 6: 9.9 ← 7: 9.8 ← 8: 10.0 ← 9: 10.3 ← 10: 10.7x ↓ <hr/> Serie 102.9 Total 102.9	60 Skud 	11: 10.7x ← 12: 10.4x ↑ 13: 10.1 ↓ 14: 10.8x ↗ 15: 10.1 ↓ 16: 10.3 ↓ 17: 10.7x → 18: 9.8 ↓ 19: 9.7 ↗ 20: 9.1 ↘ <hr/> Serie 101.7 Total 204.6
--	--	--	---

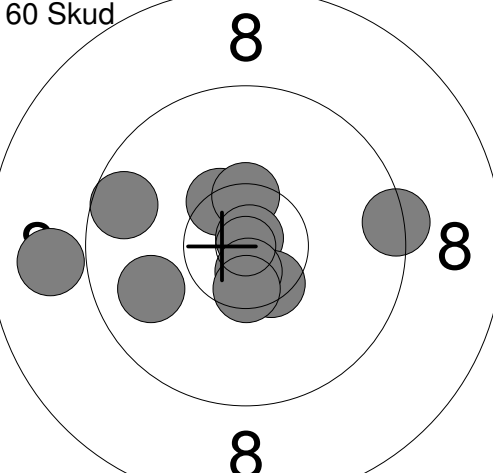
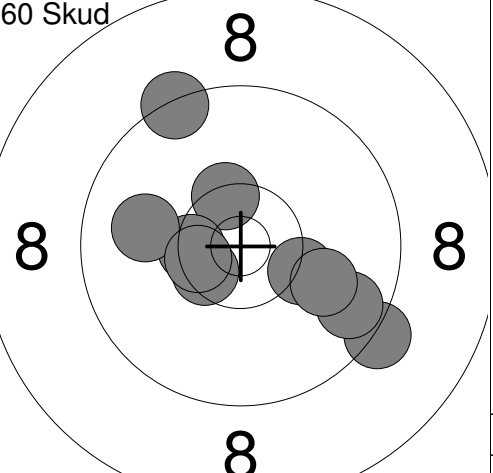
60 Skud 	21: 10.4x ↗ 22: 10.4x ↑ 23: 10.9x ↑ 24: 10.5x ↓ 25: 10.7x ↓ 26: 9.9 ← 27: 8.9 ← 28: 9.4 → 29: 10.5x ↓ 30: 9.6 ← <hr/> Serie 101.2 Total 305.8	60 Skud 	31: 10.4x ↑ 32: 9.3 ↘ 33: 10.5x ← 34: 9.7 ↘ 35: 10.3 → 36: 10.0 → 37: 10.4x ← 38: 9.4 ↑ 39: 9.9 ← 40: 10.5x ← <hr/> Serie 100.4 Total 406.2
---	--	---	--

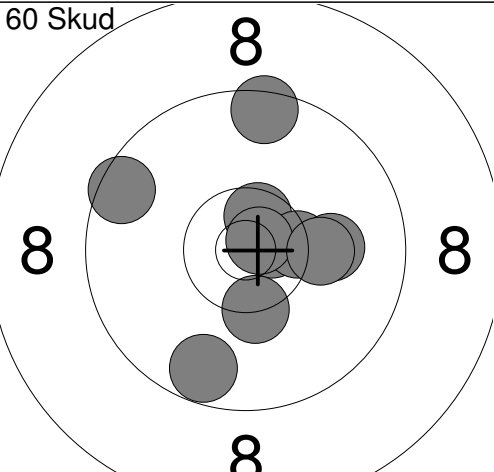
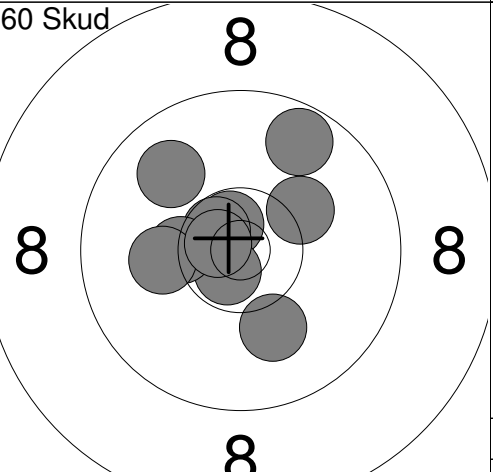
60 Skud 	41: 9.5 ↑ 42: 9.5 ← 43: 10.7x → 44: 9.7 ↓ 45: 10.6x ↑ 46: 10.4x → 47: 10.3x ↓ 48: 10.8x ↗ 49: 10.1 → 50: 10.2 → <hr/> Serie 101.8 Total 508.0	60 Skud 	51: 10.7x ↑ 52: 10.6x ↗ 53: 10.7x ↓ 54: 10.3x ← 55: 9.9 ↗ 56: 10.1 ← 57: 10.1 ↓ 58: 10.2 ↗ 59: 10.7x ← 60: 9.7 ↑ <hr/> Serie 103.0 Total 611.0
---	--	---	---

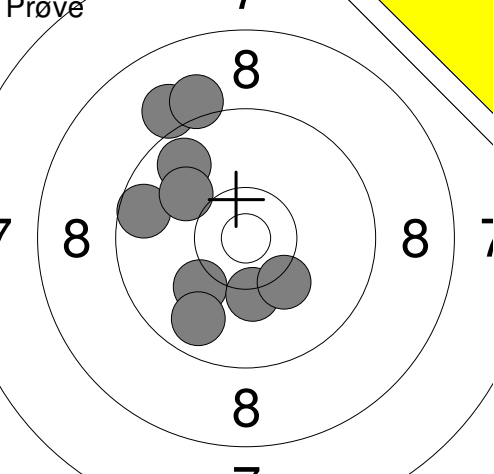
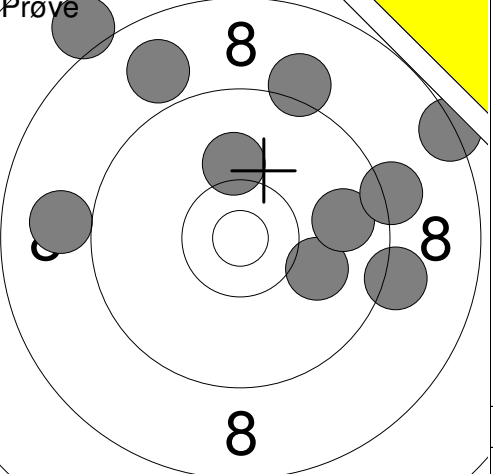
Prøve 	1: 7.2 ↗ 2: 9.6 ← 3: 9.7 ↗ 4: 9.1 ↗ 5: 10.1 ↘ 6: 9.1 ↗ 7: 9.8 ↘ 8: 10.0 ↗ 9: 10.2 ↘ 10: 10.2 ↘ Serie 95.0 Total 0.0	Prøve 	11: 10.0 → 12: 9.0 ← 13: 9.2 → 14: 8.1 ↗ 15: 9.1 ↗ 16: 9.8 → 17: 10.1 ↑ 18: 8.9 ↗ 19: 8.3 → 20: 9.2 → Serie 91.7 Total 0.0
---	--	---	---

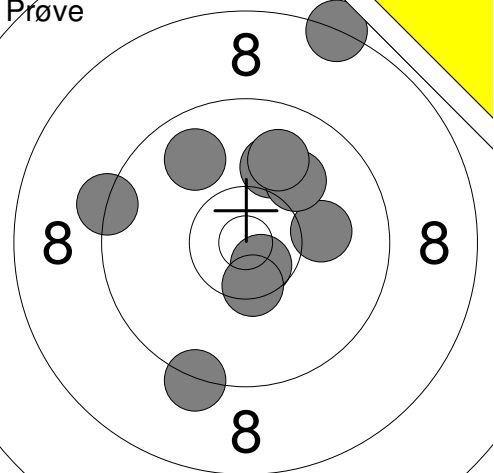
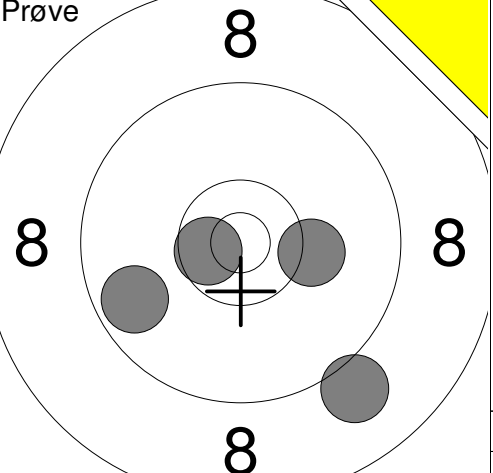
Prøve 	21: 9.8 ↗ 22: 10.1 → 23: 10.0 ↗ 24: 8.3 ↗ 25: 10.0 ↗ 26: 10.6x ↘ 27: 10.5x ↘ 28: 9.3 ↘ 29: 9.3 ← 30: 9.9 ↗ Serie 97.8 Total 0.0	Prøve 	31: 10.2 → 32: 9.7 ← 33: 9.0 ↘ 34: 10.6x ← Serie 39.5 Total 0.0
--	--	--	--

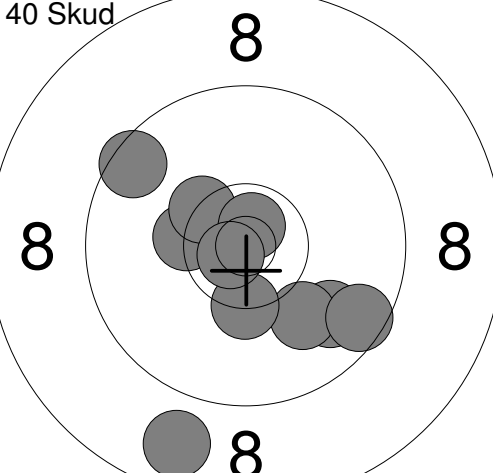
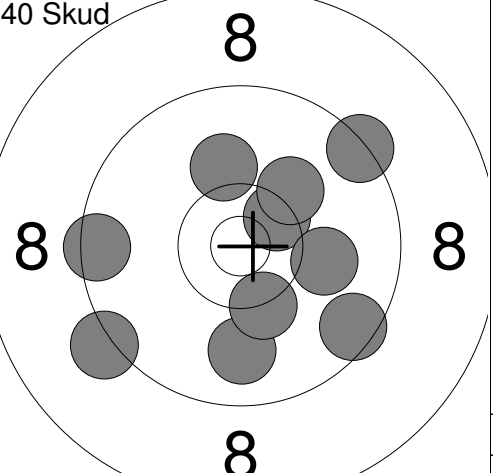
40 Skud 	1: 9.8 ↘ 2: 10.3x ← 3: 10.4x ↗ 4: 10.0 ↘ 5: 9.5 ↗ 6: 10.7x ↗ 7: 10.3x ↘ 8: 9.6 ↘ 9: 10.8x ← 10: 8.8 ↘ Serie 100.2 Total 100.2	40 Skud 	11: 9.9 ↓ 12: 10.3x ↓ 13: 10.1 ↑ 14: 10.5x ↗ 15: 9.2 ← 16: 9.5 ← 17: 9.5 ↘ 18: 9.4 ↗ 19: 10.2 ↗ 20: 10.1 → Serie 98.7 Total 198.9
---	--	---	--

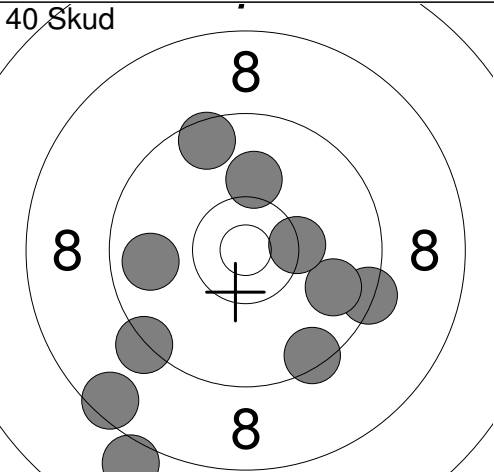
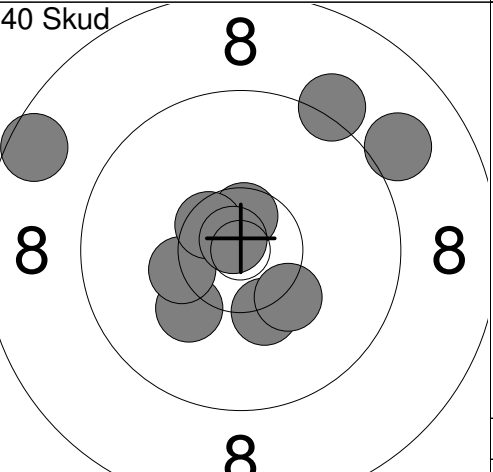
40 Skud 	21: 9.4 → 22: 9.8 → 23: 10.3x → 24: 9.4 ↘ 25: 8.5 ↘ 26: 8.0 ↘ 27: 9.5 ↗ 28: 10.1 ↑ 29: 9.8 ← 30: 9.3 ↘ Serie 94.1 Total 293.0	40 Skud 	31: 10.3 ↓ 32: 10.2 ↘ 33: 10.6x ↑ 34: 10.3 ↘ 35: 10.3x ← 36: 9.2 ↗ 37: 9.0 ↗ 38: 10.5x ↗ 39: 10.8x ↗ 40: 8.6 ← Serie 99.8 Total 392.8
---	--	---	--

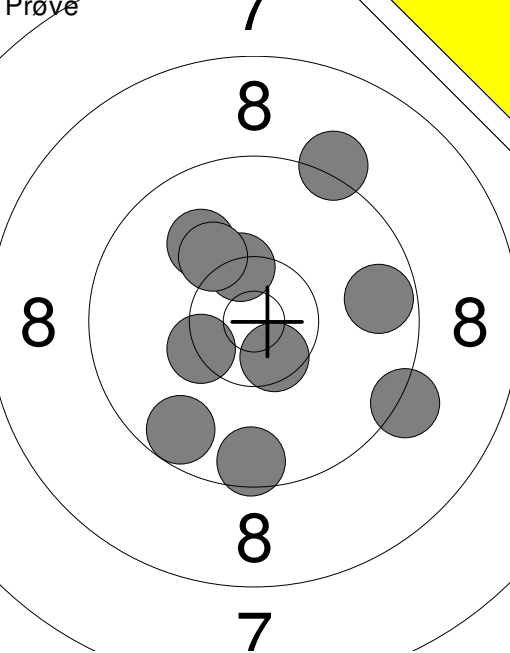
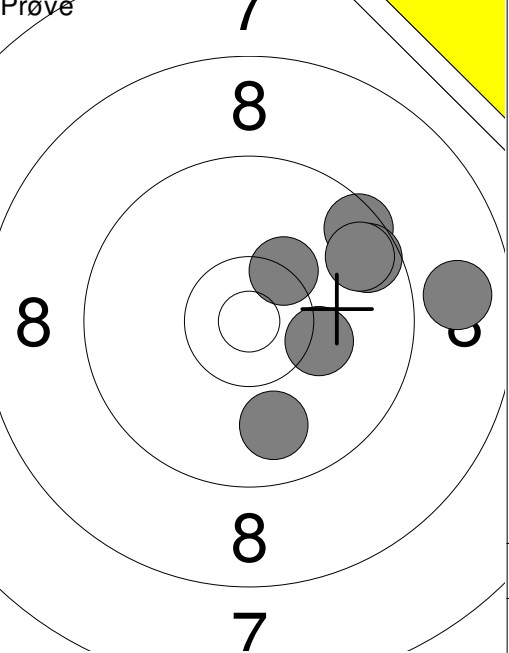
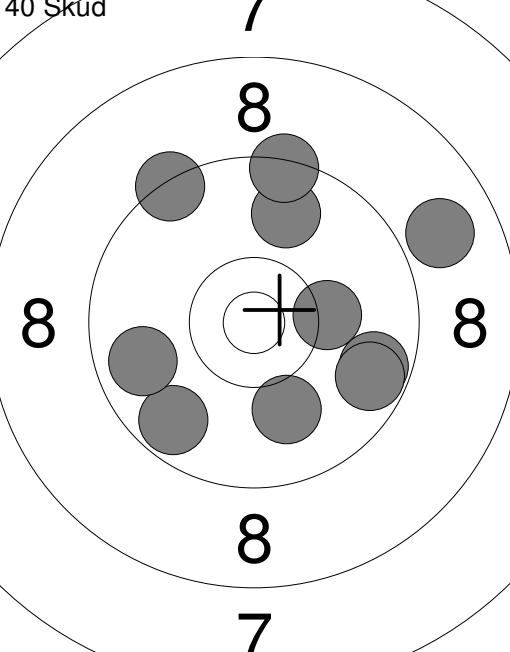
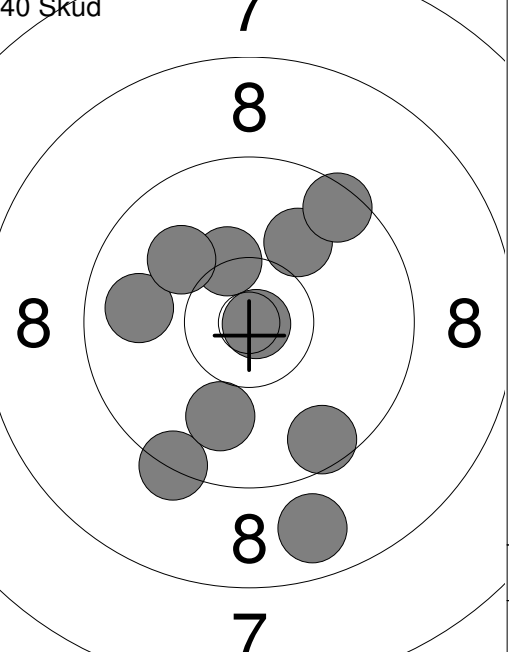
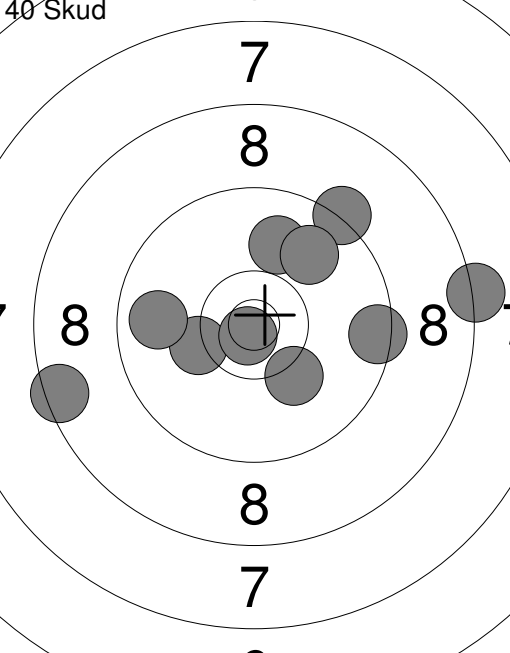
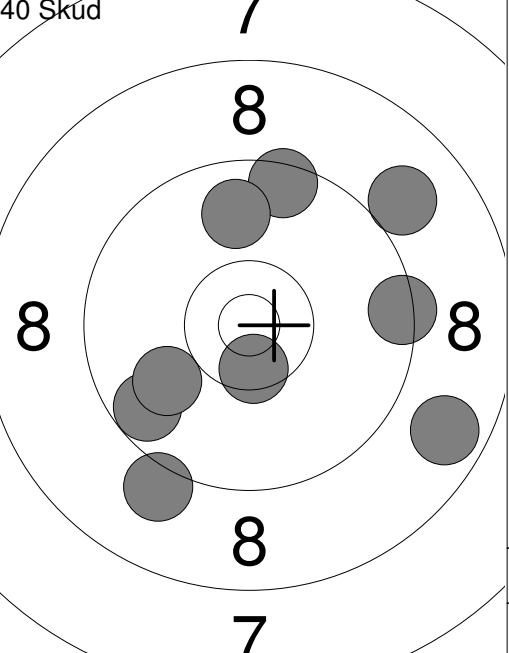
Prøve 	1: 9.6 ↓ 2: 9.6 ↙ 3: 10.0 ↖ 4: 9.2 ↗ 5: 10.4x ↗ 6: 10.4x ↙ 7: 9.2 → 8: 10.2 ↗ 9: 9.7 → 10: 10.5x ↓ <hr/> Serie 98.8 Total 0.0	Prøve 	11: 9.5 ↗ 12: 10.2 → 13: 8.9 → 14: 10.3x ↗ 15: 9.6 ↗ 16: 9.7 ↗ 17: 9.9 ↓ <hr/> Serie 68.1 Total 0.0
40 Skud 	1: 9.7 ↙ 2: 9.8 ← 3: 9.8 ↗ 4: 9.4 ↗ 5: 8.9 → 6: 9.4 ↗ 7: 9.7 → 8: 10.0 ↓ 9: 9.7 → 10: 10.2 → <hr/> Serie 96.6 Total 96.6	40 Skud 	11: 10.3x ↗ 12: 9.3 ↓ 13: 9.9 ← 14: 9.6 ↓ 15: 8.8 ↓ 16: 10.0 ↖ 17: 10.0 ↗ 18: 9.5 ↗ 19: 10.9x → 20: 10.0 ↓ <hr/> Serie 98.3 Total 194.9
40 Skud 	21: 10.2 ← 22: 10.2 ↓ 23: 9.8 ← 24: 8.3 → 25: 10.8x ↓ 26: 9.3 ↗ 27: 9.9 ↗ 28: 9.5 → 29: 9.9 ↗ 30: 8.5 ← <hr/> Serie 96.4 Total 291.3	40 Skud 	31: 9.7 ↙ 32: 9.1 ↓ 33: 9.0 ↗ 34: 9.5 ↗ 35: 9.8 ↗ 36: 9.4 → 37: 10.5x ↓ 38: 8.7 → 39: 10.0 ↙ <hr/> Serie 85.7 Total 377.0

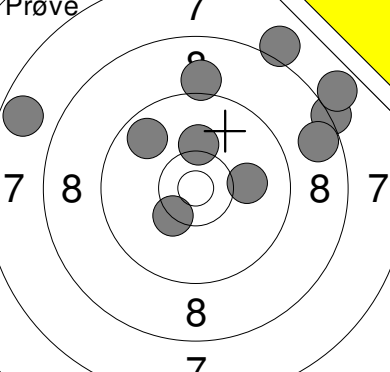
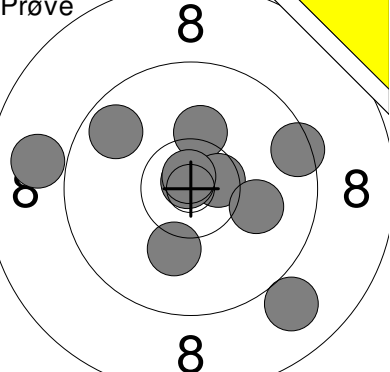
Prøve 7		Prøve 8	
	1: 8.1 ↑ 2: 10.1 → 3: 9.1 ↑ 4: 8.3 → 5: 8.0 → 6: 8.7 → 7: 7.7 ← 8: 9.7 ↑ 9: 10.2 ↑ 10: 10.3x ↑		11: 10.2 ↑ 12: 10.6x → 13: 9.7 ↗ 14: 9.5 → 15: 10.9x ↗ 16: 8.9 ← 17: 9.0 ↘ 18: 10.1 ↘ 19: 10.8x ↑ 20: 10.1 ↓
Serie	90.2	Serie	99.8
Total	0.0	Total	0.0

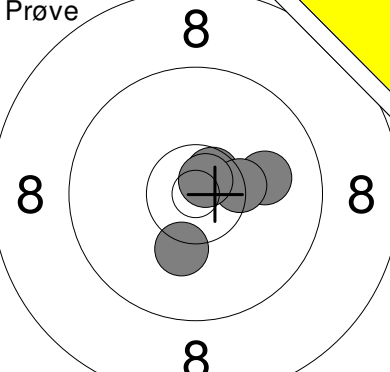
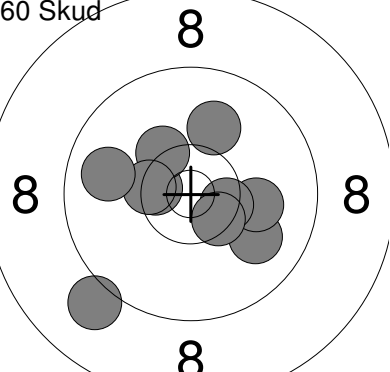
Prøve 8		60 Skud 8	
	21: 10.0 → 22: 10.6x ↗ 23: 10.4x → 24: 10.7x ↗ 25: 10.2 ↓		1: 10.0 ↑ 2: 9.9 ↘ 3: 10.5x ← 4: 10.3x ↗ 5: 10.1 → 6: 9.1 ↘ 7: 10.5x ↘ 8: 10.5x ↘ 9: 10.4x ↗ 10: 9.9 ←
Serie	51.9	Serie	101.2
Total	0.0	Total	101.2

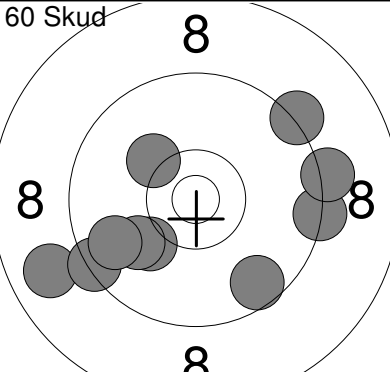
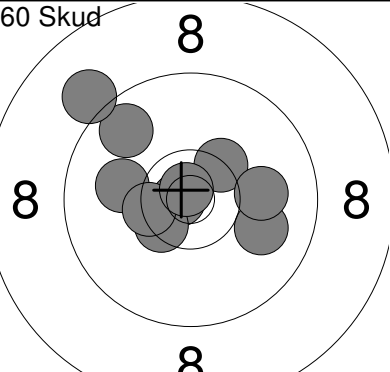
60 Skud 8		60 Skud 8	
	11: 10.1 ↘ 12: 8.8 ← 13: 10.0 ← 14: 9.4 ← 15: 9.6 ↘ 16: 10.2 ↗ 17: 9.8 ← 18: 9.3 → 19: 9.3 ↗ 20: 9.2 →		21: 10.4x ↗ 22: 10.8x ← 23: 10.0 ↘ 24: 10.1 ← 25: 9.7 ↗ 26: 10.4x ↘ 27: 10.4x ← 28: 10.0 → 29: 10.8x ↗ 30: 9.1 ↗
Serie	95.7	Serie	101.7
Total	196.9	Total	298.6

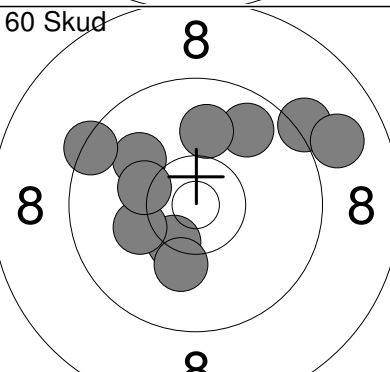
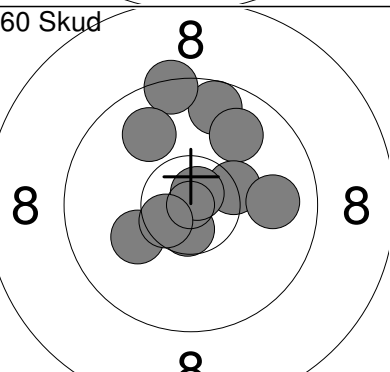
60 Skud 8		60 Skud 8	
	31: 10.4x ↘ 32: 10.0 ↗ 33: 10.2 ↘ 34: 10.2 ← 35: 9.8 ↗ 36: 9.2 ↗ 37: 9.4 ↗ 38: 10.0 ↑ 39: 10.2 ← 40: 8.9 →		41: 9.6 ↑ 42: 9.9 ↗ 43: 10.3x → 44: 9.9 → 45: 10.1 ← 46: 10.6x ↓ 47: 9.4 ↑ 48: 10.8x ↗ 49: 10.6x ← 50: 9.9 ↗
Serie	98.3	Serie	101.1
Total	396.9	Total	498.0

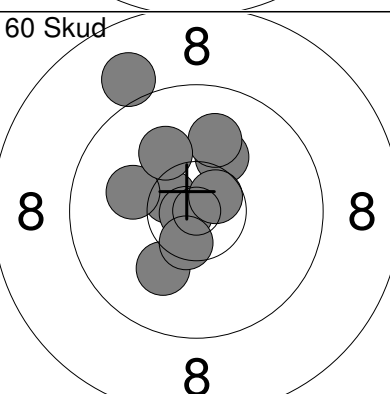
60 Skud 8			
	51: 10.2 ↗ 52: 10.5x ↗ 53: 10.8x ← 54: 9.0 ↗ 55: 10.6x ↗ 56: 10.1 ← 57: 10.0 ↗ 58: 10.1 ↗ 59: 10.1 ↘ 60: 10.5x ↓		
Serie	101.9		
Total	599.9		